



1973-79 Ford F-Series/ 1978-79 Bronco

Heavy-Duty Condenser Kit *with* Drier
(011156)



18865 Goll St. San Antonio, TX 78266
Phone: 800-862-6658
Sales: sales@vintageair.com
Tech Support: tech@vintageair.com
www.vintageair.com



www.vintageair.com

Table of Contents

| | |
|---|----|
| Cover..... | 1 |
| Table of Contents/Parts Disclaimer..... | 2 |
| Important Notice-Please Read..... | 3 |
| Important Information Before Beginning, Core Support Reference..... | 4 |
| Engine Compartment Disassembly..... | 5 |
| Engine Compartment Disassembly(Cont.)..... | 6 |
| Radiator Removal: Standard Core Support, Core Support Modification (6-Cylinder Only)..... | 7 |
| Condenser Installation: Standard Core Support..... | 8 |
| Condenser Installation: Standard Core Support (Cont.)..... | 9 |
| Radiator Modification: 4x4 Core Support..... | 10 |
| Condenser Installation: 4x4 Core Support..... | 11 |
| Condenser Installation: 4x4 Core Support (Cont.)..... | 12 |
| Lubricating O-rings, Binary Switch Installation, Hardline & Drier Installation..... | 13 |
| Hardline & Drier Installation (Cont.)..... | 14 |
| Final Steps..... | 15 |
| Packing List..... | 16 |

Parts Disclaimer: Please Read

Before beginning installation, open all packages and check contents of shipment. Please report any shortages directly to Vintage Air within 15 days. After 15 days, Vintage Air will not be responsible for missing or damaged items. Packing list located on last page of instructions.



www.vintageair.com

Important Notice—Please Read

For Maximum System Performance, Vintage Air Recommends the Following:

NOTE: Vintage Air systems are designed to operate with R134a refrigerant only. Use of any other refrigerant could damage your A/C system and/or vehicle, and possibly cause a fire, in addition to potentially voiding the warranties of the A/C system and its components.

Refrigerant Capacities:

Vintage Air System: 1.8 lbs. (28.8 oz.) or 816 grams of **R134a**, charged by weight with a quality charging station or scale. **NOTE: Use of the proper type and amount of refrigerant is critical to system operation and performance.**

Other Systems: Consult manufacturer's guidelines.

Lubricant Capacities:

New Vintage Air-Supplied Sanden Compressor: No additional oil needed (Compressor is shipped with proper oil charge).

All Other Compressors: Consult manufacturer (Some compressors are shipped dry and will need oil added).

Safety Switches

Your Vintage Air system is equipped with a binary pressure safety switch. A binary switch disengages the compressor clutch in cases of extreme low pressure conditions (refrigerant loss) or excessively high head pressure (406 PSI) to prevent compressor damage or hose rupture. A trinary switch combines Hi/Lo pressure protection with an electric fan operation signal at 254 PSI, and should be substituted for use with electric fans. Compressor safety switches are extremely important since an A/C system relies on refrigerant to circulate lubricant.

Service Info:

Protect Your Investment: Prior to assembly, it is critical that the compressor, evaporator, A/C hoses and fittings, hardlines, condenser and receiver/drier remain capped. Removing caps prior to assembly will allow moisture, insects and debris into the components, possibly leading to reduced performance and/or premature failure of your A/C system. This is especially important with the receiver/drier.

Additionally, when caps are removed for assembly, **BE CAREFUL!** Some components are shipped under pressure with dry nitrogen.

Evacuate the System for 35-45 Minutes: Ensure that system components (Drier, compressor, evaporator and condenser) are at a temperature of at least 85°F. On a cool day, the components can be heated with a heat gun **or** by running the engine with the heater on before evacuating. Leak check and charge to specifications.

Bolts Passing Through Cowl and/or Firewall:

To ensure a watertight seal between the passenger compartment and the vehicle exterior, for all bolts passing through the cowl and/or firewall, Vintage Air recommends coating the threads with silicone prior to installation.

Heater Hose (not included with this kit):

Heater hose may be purchased from Vintage Air (Part#31800-VUD) or your local parts retailer. Routing and required length will vary based on installer preference.



www.vintageair.com

Important Information Before Beginning:

- This heavy-duty condenser kit was developed with the cross compatibility between two different kinds of radiator core supports in mind. The first core support variant is the "Standard Core Support", with the second variant being the "4 x 4 Core Support." Both share similar features but have different configurations for mounting the radiator. Confirm which core support your vehicle is equipped with to utilize the correct installation procedure.
- The "4 x 4 Core Support" will have a stand-off brace manufactured onto the core support (See Photo 2, below).
- The "Standard Core Support" will not have the stand-off brace as shown in Photo 3, below.
- The 6-cylinder core support opening will be smaller than the V8 core support opening. If the core support opening width is less than 27 5/8" (See Photo 1, below), it will need to be modified by following the steps on Page 8.
- The Engine Compartment Disassembly procedures on Pages 5 and 6 will be followed for both the "Standard" and "4 x 4" core supports.
- For sufficient engine cooling and proper airflow through the 14" x 25" condenser supplied with this kit, it will be necessary to replace the 6-cylinder OEM radiator with a higher-capacity V8-style radiator.
- For optimal cooling performance, Vintage Air recommends using a fan shroud. When using a shroud with an OEM engine fan, be sure the fan blade is 2/3 inside the shroud, using spacers as needed for proper blade alignment.

Core Support Reference

This kit was developed based on the measurements below, which were taken from a 1977 Ford Truck and 1979 Ford Bronco with factory air.

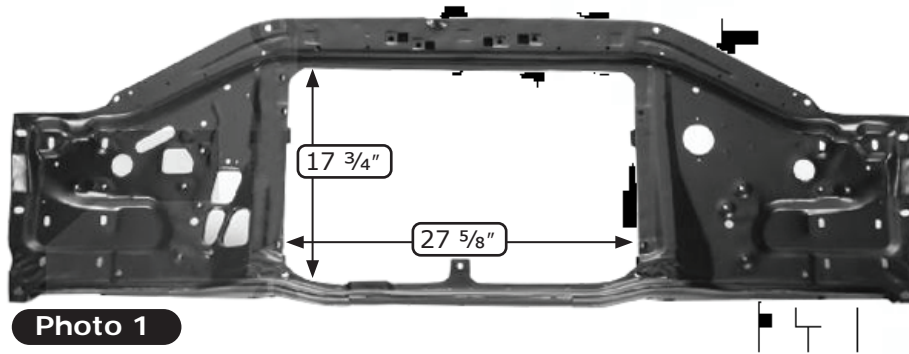

Photo 1



Photo 2

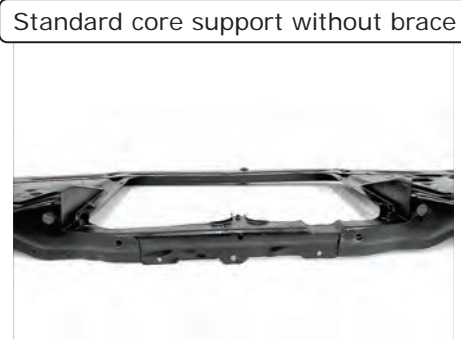

Photo 3



www.vintageair.com

Engine Compartment Disassembly

NOTE: Before starting the installation, check the function of the vehicle (horn, lights, etc.) for proper operation, and study the instructions, illustrations, & diagrams. Retain all OEM bolts, washers and nuts, as some hardware will be reused. Some steps will only apply to factory A/C trucks.

Perform the following:

1. Disconnect the battery.
2. Evacuate the A/C system (if equipped).
3. Remove the grille insert hardware and grille insert(s) (See Photo 1, below).
4. Remove (4) grille bracket bolts (See Photo 2, below).
5. Remove (2) hood latch assembly bolts (See Photo 3, below).
6. Remove (3) hood latch assembly core support bracket bolts ((2) upper and (1) lower) (See Photos 3 and 4, below).
7. Remove (2) #8 A/C line bracket screws and the bracket (See Photo 5, below).
8. Disconnect the OEM #6 A/C hardline from the drier (See Photo 6, below).
9. Disconnect the OEM #8 A/C hardline from the condenser (See Photo 7, below).

Remove grille insert hardware and grille insert(s)

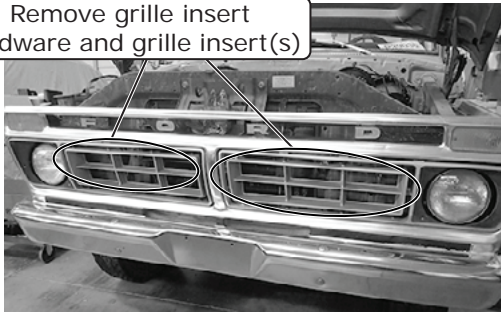

Photo 1

Remove (4) grille bracket bolts

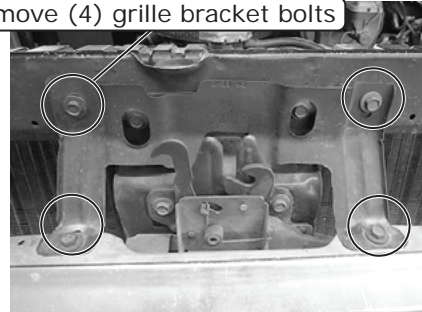

Photo 2

Remove (2) hood latch assembly bolts

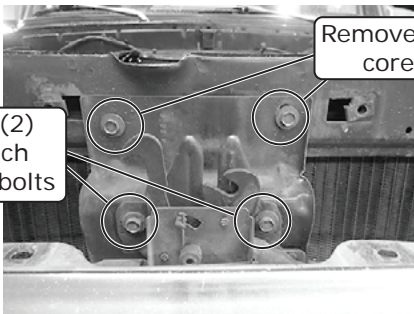

Photo 3

Remove (3) hood latch assembly core support bracket bolts

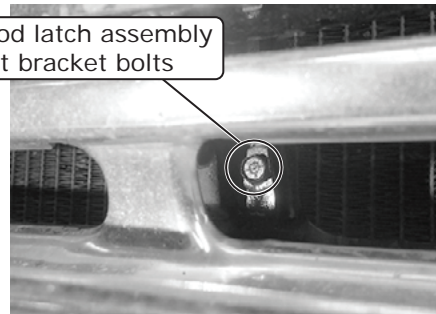

Photo 4

Remove (2) #8 A/C line bracket screws and bracket

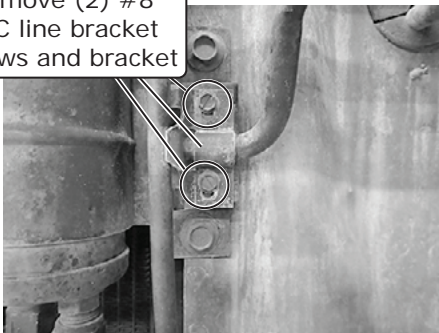

Photo 5

Disconnect OEM #6 A/C hardline from drier

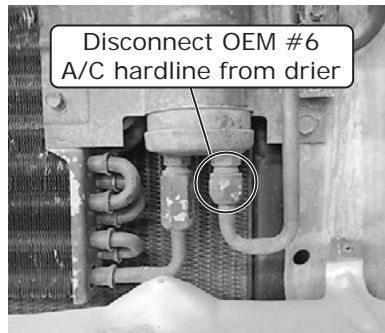

Photo 6

Disconnect OEM #8 A/C hardline from condenser

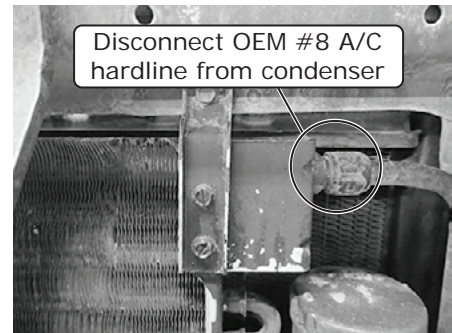

Photo 7



www.vintageair.com

Engine Compartment Disassembly (Cont.)

10. Remove (3) driver side condenser mounting bolts ((2) bolts on the drier/condenser bracket and (1) bolt on the upper bracket) (See Photos 8 and 9, below).
11. Remove (2) passenger side condenser mounting bolts (See Photos 10 and 11, below).
12. Remove the condenser assembly from the vehicle (discard).
13. Remove the OEM U-nut from the lower middle hood latch mounting bracket (See Photo 12, below). Substitute the OEM U-nut (if equipped) with the supplied 1/4-20 U-nut.
14. On the engine side of the core support, disconnect the #6 A/C hose from the condenser hardline (See Photo 13, below).
15. Disconnect the #8 condenser A/C hose from the compressor (See Photo 14, below).
16. Remove (2) grommet bracket screws (See Photo 15, below).
17. Remove the hardlines and A/C hoses (See Photo 15, below).

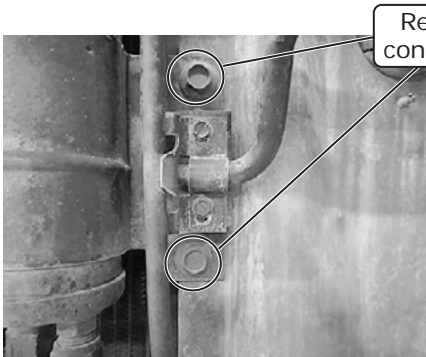

Photo 8

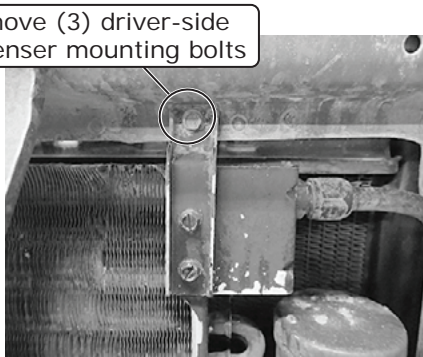

Photo 9

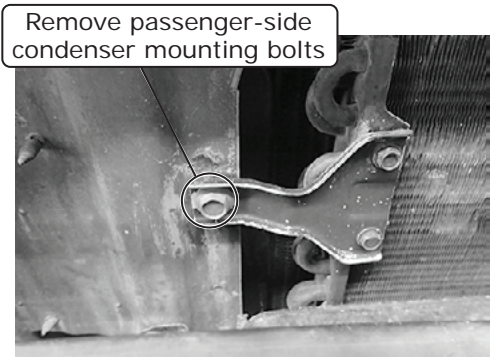

Photo 10

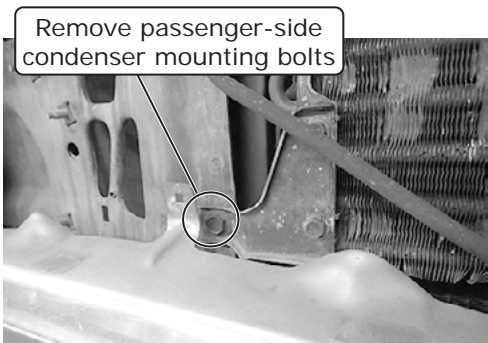

Photo 11

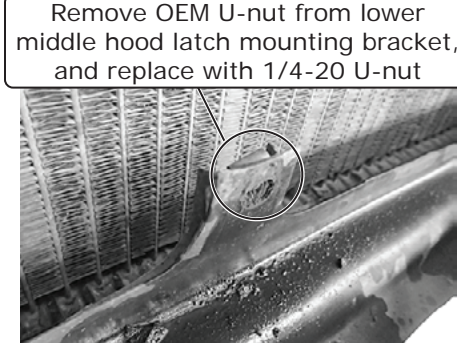

Photo 12

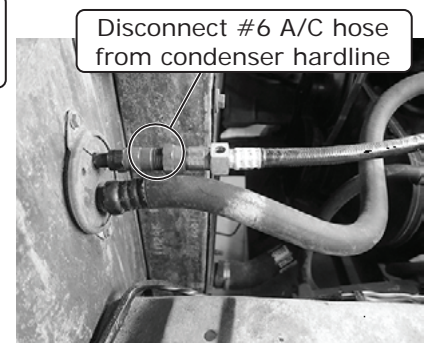

Photo 13

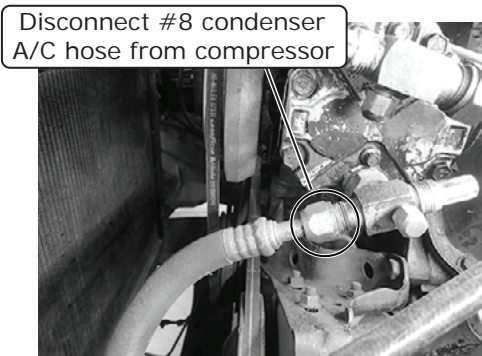

Photo 14

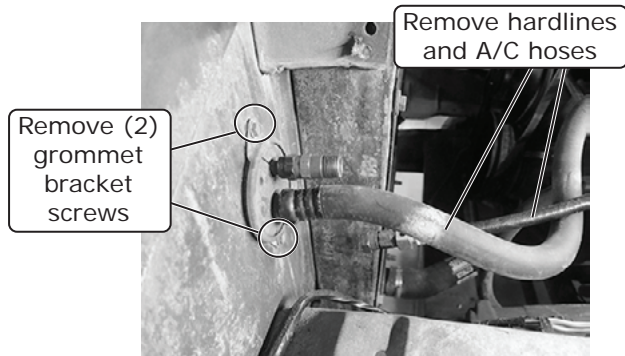

Photo 15



www.vintageair.com

Radiator Removal: Standard Core Support

NOTE: The following steps outline for only "Standard Core Supports". If your Truck/Bronco utilizes the "4x4 Core Support", proceed to Page 10.

1. Drain the coolant.
2. Disconnect the radiator hoses from the radiator.
3. Remove the radiator cooling fan by removing (4) bolts from the fan (See Photo 1, below).
4. Remove the OEM fan shroud by removing (4) bolts ((2) on each side) (if equipped).
5. Remove the radiator by removing the (4) radiator mounting bolts, (2) on each side (See Photos 2 & 3, below).

Remove radiator cooling fan by removing (4) bolts



Photo 1

Remove (4) OEM radiator mounting bolts

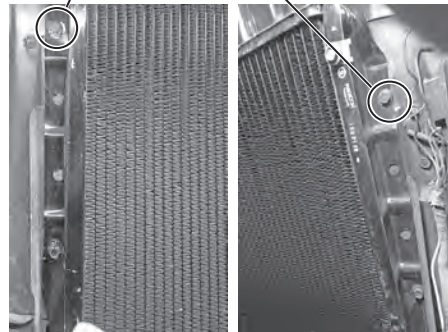

Photo 2

Photo 3

Core Support Modification (6-Cylinder Core Support Only)

NOTE: The following steps outline the modification required for 6-cylinder core support openings with a width of less than 27 5/8". For core supports that measure 27 5/8", proceed to Page 8 for Condenser Installation: Standard Core Support or Page 10 for the 4x4 installation. Disclaimer: Some core supports may appear different than the core support shown in the Photos below.

1. Measure 27 5/8" from the passenger side of the core support opening to the driver side (See Photo 1, below or Photo 1, Page 4).
2. Mark and trim the core support as shown in Photos 1 & 2, below.

Trim Core Support

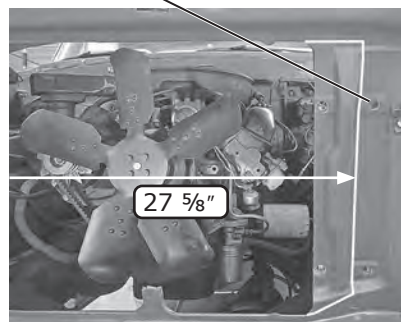

Photo 1



Photo 2



www.vintageair.com

Condenser Installation: Standard Core Support

1. Locate the driver- & passenger-side condenser mounting brackets, (8) 10-24 x 1/2" square-neck carriage bolts, (4) 10-24 nuts with star washers, (8) 3/16" push-on rings, and (4) 5/16" U-nuts (See Photo 1, below).
2. Install the 5/16" U-nuts onto the core support (See Photo 2, below). If equipped with OEM U-nuts, verify the 5/16-18 bolts are compatible.
3. Insert the (4) 10-24 x 1/2" square-neck bolts through each of the square windows from the bottom side of the brackets (See Photo 3, below), then press fit a single 3/16" push-on ring over the threaded side of the bolt. **NOTE: For best low profile condenser clearance, insert the 3/16" push-on ring face down where the smooth round surface is resting against the bracket surface. This will keep the condenser side braces flat to the mating surface of the brackets (See Figure 1, below). Use a 1/4" drive socket and the nearest socket size to press the push-on ring down evenly and with ease.**
4. Insert the (4) 10-24 x 1/2" square-neck carriage bolts to catch bracket, and thread the (4) 10-24 nut with star washers as illustrated (See photo 4, below).

(8) 10-24 x 1/2"
Square-neck carriage bolts

Passenger-side condenser
bracket 647193

(4) 10-24
Nuts with
star washers

(8) 3/16"
Push-on
rings

(4) 5/16"
U-nuts

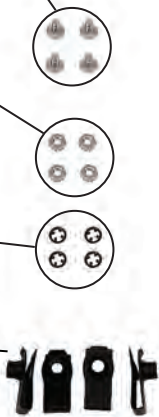
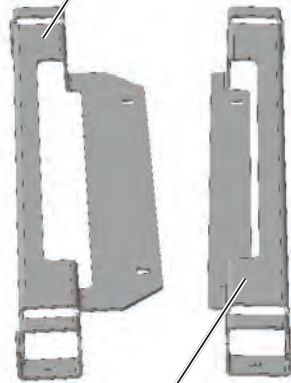

Photo 1



Driver-side condenser
bracket 647191

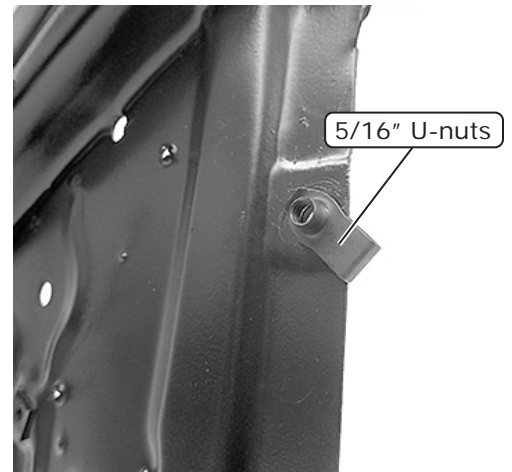

Photo 2

Grille Side View

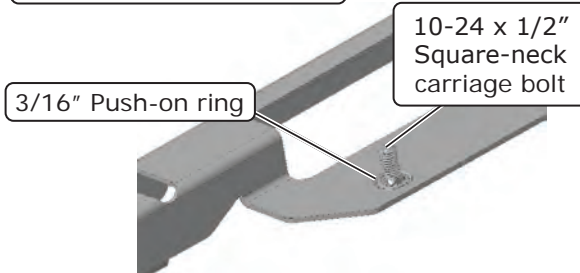

Photo 3

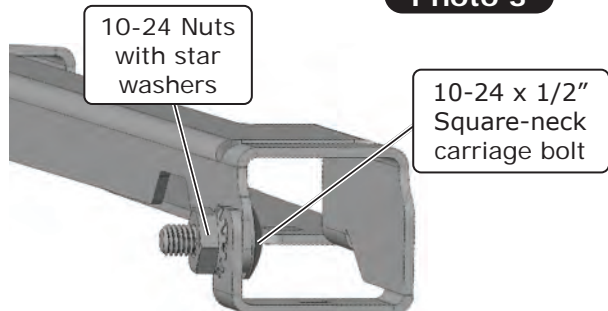

Photo 4

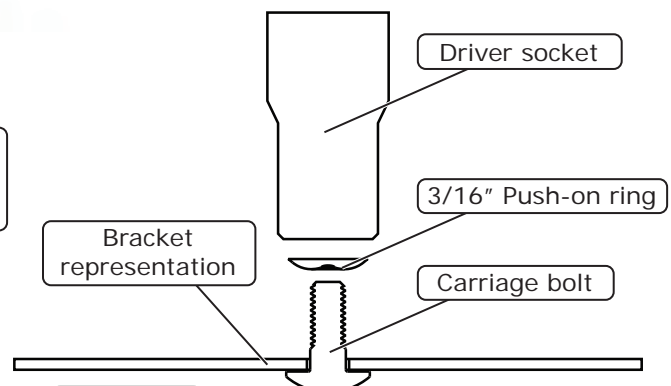

Figure 1



www.vintageair.com

Condenser Installation: Standard Core Support (Cont.)

5. Replace the vehicle's radiator back into the engine compartment, while keeping about a 1" gap from the core support. **NOTE: This gap is where the condenser brackets will rest and make up the distance between.**
6. Place a condenser bracket according to its driver- & passenger-side orientation (See Photo 5, below).
7. Locate (4) 5/16-18 x 1 3/4" hex bolts, (4) 5/16" lock washers and (4) 5/16" USS flat washers. Gather one of each item and assemble. Then, install the assembled fasteners through the radiator, condenser bracket, and U-nut (See Photo 6 and Figure 2, below). Leave bolts loosely fitted. **NOTE: Leaving bolts loosely will allow brackets to shift left and right to ease condenser installation.**
8. Shift both condenser brackets to the furthest point on the passenger side of the core support, then start with securing the driver-side bracket to the condenser first (See Photo 7 & 8, below). **NOTE: This will allow proper clearance to place a wrench onto nuts to secure the condenser. This can be difficult with the minimum clearance available between the core support and condenser bracket. We recommend to Dremel, or die grind a clearance that follows the path to sit a socket for ease of installation.**
9. Place the condenser against both brackets, then secure it with (4) 10-24 nuts with star washers (See Photo 9, below). **Disclaimer: Do not over tighten! NOTE: The Feed (#8 Fitting Port) and Exit (#6 Fitting Port) need to be correctly orientated.**
10. Shift the condenser and bracket assembly to the driver side of the core support. **NOTE: Keep the radiator mounting bolts loosely fitted until further instructed.**
11. Proceed to Page 13 to continue with the installation.

Place condenser bracket according to driver & passenger orientation

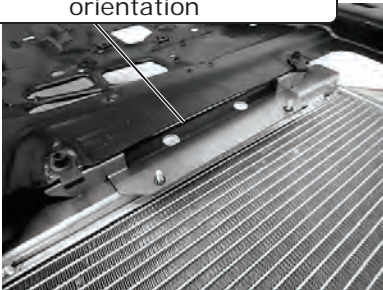

Photo 5

Install assembled fasteners through radiator

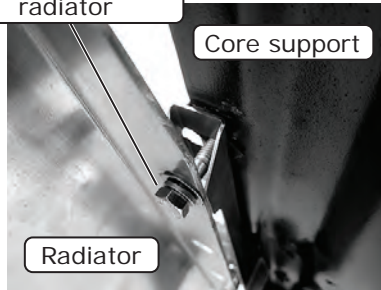

Photo 6

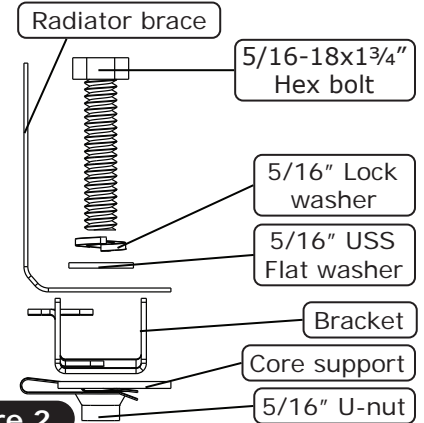

Figure 2

Shift both condenser brackets to the furthest point to the passenger side



Photo 7

Grille Side View

Start with the driver-side bracket to secure the condenser

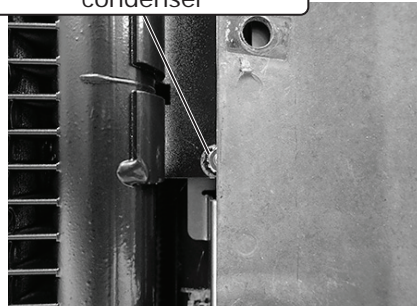

Photo 8

Place condenser against brackets and secure with (4) 10-24 nuts with star washers

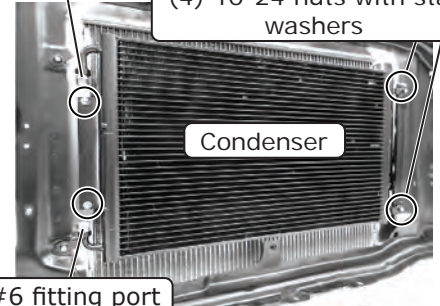

Photo 9



www.vintageair.com

Radiator Modification: 4x4 Core Support

1. Remove both the upper and lower radiator mounting bolts (See Photo 1, below).
2. Install (4) 1/4" length spacers between the core support and the radiator. Each 1/4" spacer is secured using (4) 5/16-18 x 1" hex bolts and (4) 1/4" USS flat washers at both the upper and lower mounting locations (See Figure 1 and Photo 2, below).
3. Tighten all bolts to secure the radiator in place.

Remove radiator
mounting bolts



Photo 1

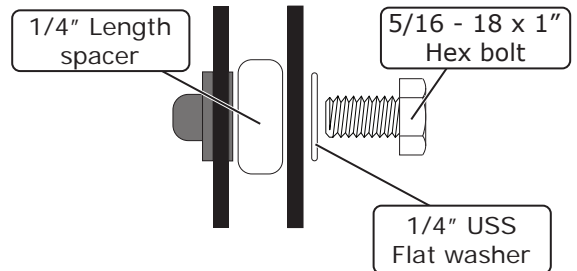

Figure 1

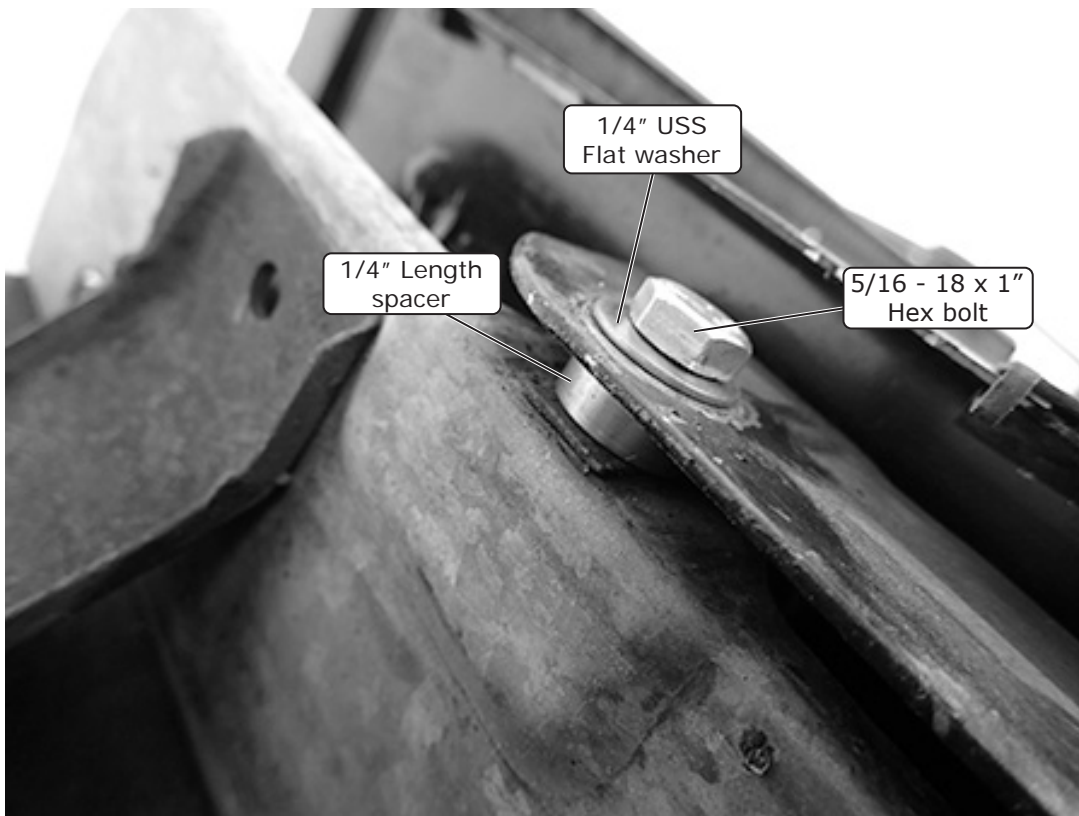

Photo 2



www.vintageair.com

Condenser Installation: 4x4 Core Support

1. Locate the driver- & passenger-side condenser mounting brackets, (4) 10-24 x 1/2" square-neck carriage bolts, (4) 10-24 nuts with star washers, (4) 3/16" push-on rings, and (4) 5/16" U-nuts (See Photo 1, below).
2. Install the (4) 5/16" U-nuts onto the condenser brackets (See Photo 2, below).
3. Insert the (4) 10-24 x 1/2" square-neck carriage bolts through each of the square windows from the bottom side of the brackets as shown in Photo 3, below, then press fit 3/16" push-on rings over the threaded side of the square bolt. **NOTE: For best low profile Condenser clearance, insert the 3/16" push-on ring face down, where the smooth round surface is resting against the bracket surface. This will keep the condenser side braces flat to the mating surface of the brackets (See Figure 1, below). Use a 1/4" drive socket and the nearest socket size to press the ring down evenly and with ease.**
4. Place the condenser brackets according to their driver- & passenger-side orientation (See Photo 4, below).

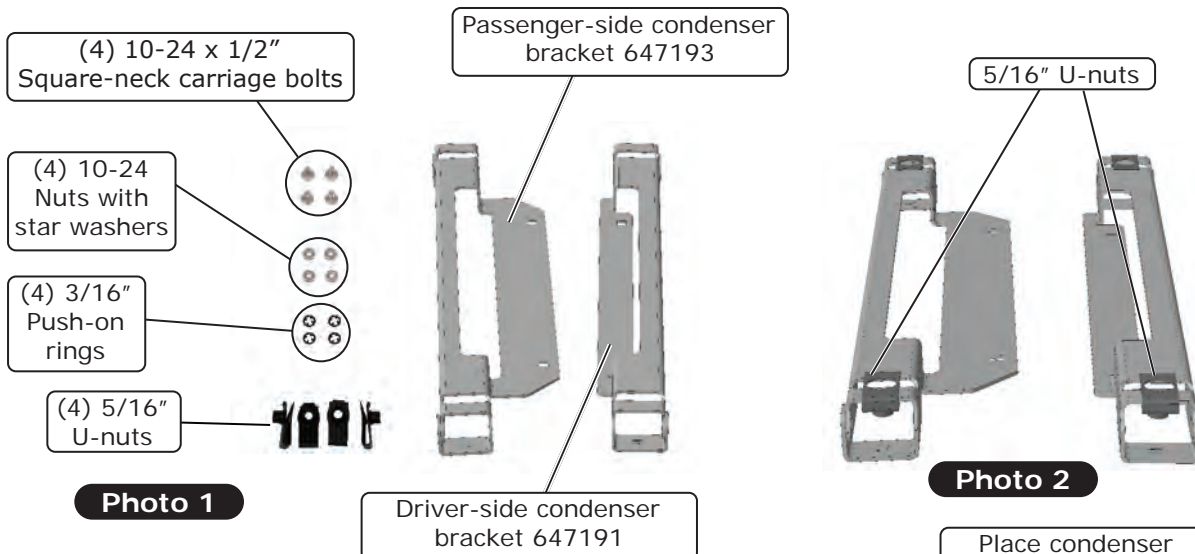

Photo 1

Photo 2

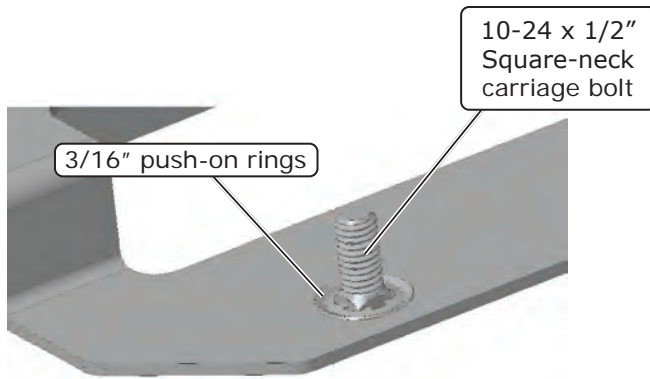

Photo 3

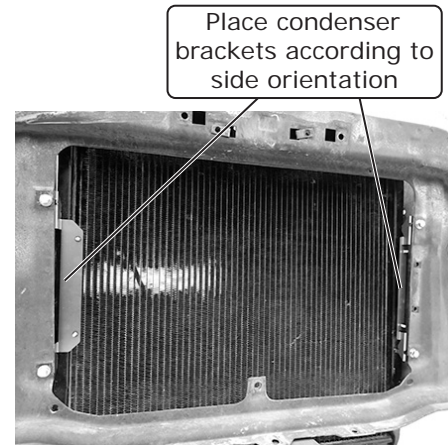

Photo 4

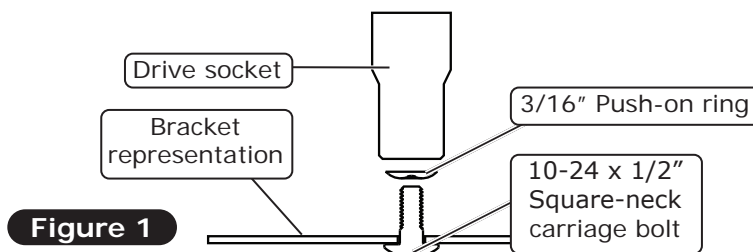

Figure 1



www.vintageair.com

Condenser Installation: 4x4 Core Support (Cont.)

5. Locate (4) 5/16-18 x 1" hex bolts, (4) 5/16" lock washers and (4) 5/16" flat washer. Gather one of each item and assemble. Then, install the assembled fasteners through the front side of the core support to catch the U-nut from the condenser bracket (See Photo 5, below). Leave bolts loosely fitted. **NOTE: Leaving bolts loosely will allow brackets to shift left and right for ease of condenser installation.**
6. Shift both condenser brackets to the furthest point on the passenger side of the core support, then start with the driver side bracket to secure the condenser (See Photo 6 & 7, below). **NOTE: This will allow proper clearance to place a wrench onto the nuts that secure the condenser. This can be difficult with the minimum clearance available between the core support and condenser bracket. We recommend to Dremel or die grind a clearance that follows the path to sit a socket for ease of installation.**
7. Place the condenser against both brackets, then secure it with (4) 10-24 nuts with star washers (Photo 8, below). **Disclaimer: Do not over tighten! NOTE: The Feed (#8 Fitting Port) and Exit (#6 Fitting Port) need to be correctly orientated as shown in.**
8. Shift the condenser and bracket assembly to the driver side of the core support. **NOTE: Keep the condenser mounting bolts loosely fitted until further instructed.**

Install assembled fasteners through the front side

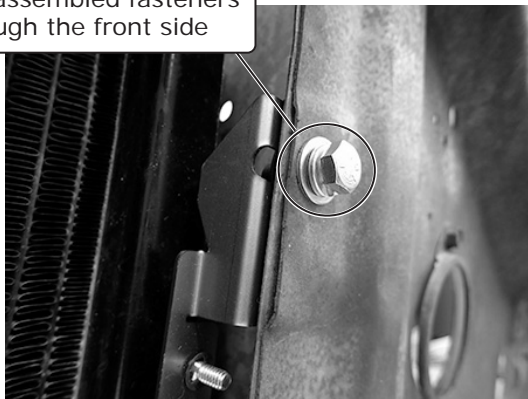

Photo 5

Shift both condenser brackets to the furthest point to the passenger side



Photo 6

Start with driver-side bracket to secure the condenser



Photo 7

#8 fitting port

Condenser brackets

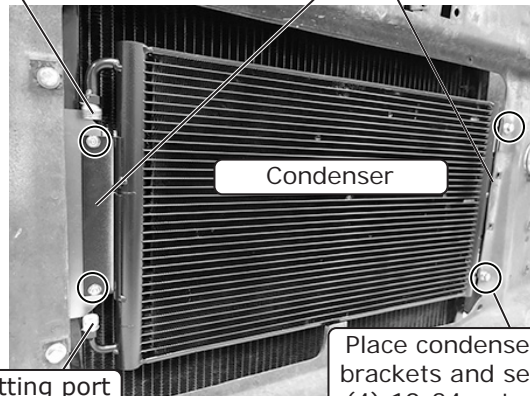

#6 fitting port

Condenser

Place condenser against brackets and secure with (4) 10-24 nuts with star washers

Photo 8



www.vintageair.com

Lubricating O-rings

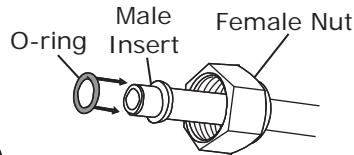
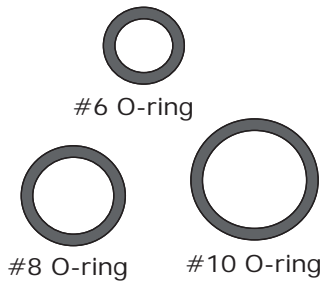

For a proper seal of fittings: Install supplied O-rings as shown and lubricate with refrigerant oil.

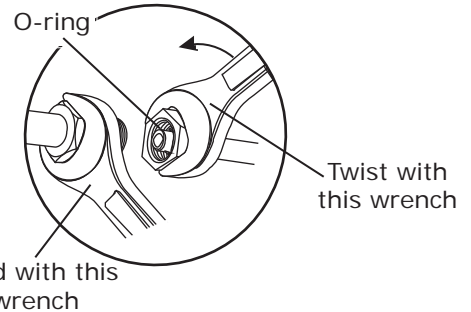
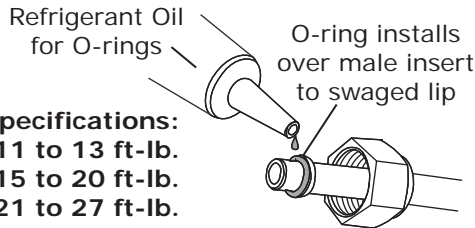

NOTE: Standard torque specifications:
 #6: 11 to 13 ft-lb.
 #8: 15 to 20 ft-lb.
 #10: 21 to 27 ft-lb.

Binary Switch Installation

NOTE: Do not remove the caps from the drier. The drier contains a desiccant that will quickly absorb moisture from the air, causing it to lose effectiveness. For this reason, Vintage Air recommends that the drier remains capped until the installer is ready to evacuate the system.

1. Lubricate the O-ring on the binary switch (See Photo 1, below). **NOTE:** The binary switch and the drier each come with an O-ring. Only use the binary switch O-ring.
2. Thread the binary switch onto the drier (See Photo 2, below).

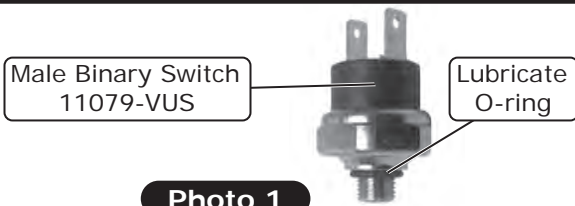

Photo 1

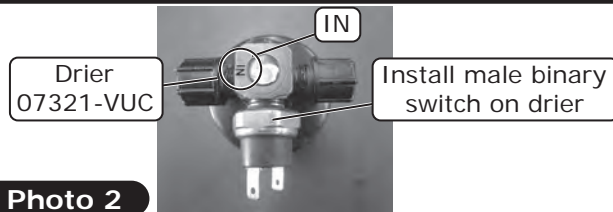

Photo 2

Hardline & Drier Installation

NOTE: The use of a backup wrench is important when installing the hardlines to avoid damage to the condenser (See Lubricating O-rings, above).

1. Lubricate (2) #6 O-rings and install (1) onto each end of the #6 condenser/drier hardline (See Lubricating O-rings, above).
2. Route the #6 condenser/drier hardline through the core support opening, then connect it to the #6 condenser fitting (See Photo 1, below). **NOTE: Do not fully tighten at this time.**
3. Locate the drier clamp and loosen the nut, then insert the drier. **NOTE: Refrigerant flow through the drier is IN from the condenser, OUT to the evaporator (See Photo 2, above). Do not tighten drier clamp hardware at this time.**
4. Install the #6 condenser/drier hardline onto the drier. **NOTE: If necessary, adjust condenser assembly left or right relative to the drier placement so the body of the drier is not pressing against the inner fenderwell, but also not too far from its new designated location for the following steps. Do not fully tighten the fitting at this time. When installing the drier, leave 1/4" between the base of the drier and the vehicle (See Photo 2, below).**

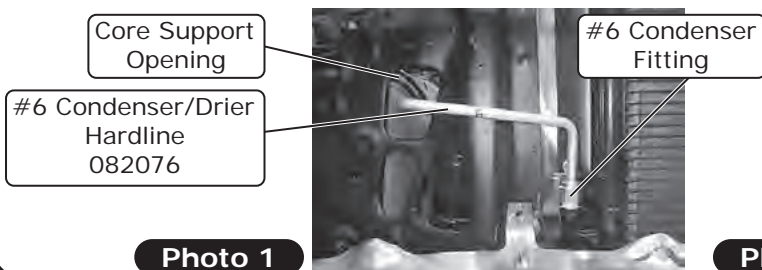

Photo 1

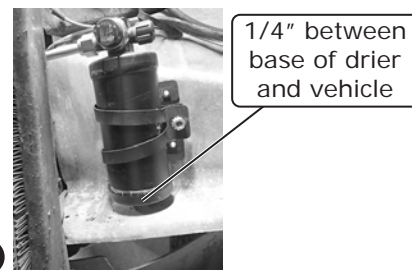

Photo 2



www.vintageair.com

Hardline & Drier Installation (Cont.)

5. Adjust the drier clamp on the inner fenderwell. Using the drier clamp as a template, mark and drill (2) 9/64" mounting holes. Secure it using (2) #10 x 1/2" sheet metal screws (See Photo 3, below).
6. Tighten the drier clamp hardware. With properly lubricated O-rings installed, tighten the #6 condenser/drier hardline connections at the drier and condenser (See Lubricating O-rings, Page 13).
7. Lubricate a #8 O-ring, and install it onto the #8 condenser/compressor hardline end that connects to the #8 condenser fitting. Install the #8 condenser/compressor hardline onto the #8 condenser fitting, routing the line through the core support opening (See Photo 4, below). **NOTE: Do not fully tighten at this time.**
8. Install a 1/2" Adel clamp onto the #8 condenser/compressor hardline (See Photo 5, below). **NOTE: The gap between the #6 and #8 hardline should be between 3/8" - 1/2".** If using an OEM transmission cooler, before securing the #4 Adel clamp to the core support, install the transmission cooler to the OEM location then secure the Adel clamp (See Photo 6, below).
9. Mark and drill a 9/64" hole into the core support, and secure the 1/2" Adel clamp using a #10 x 1/2" sheet metal screw (See Photos 5 & 7, below). **NOTE: Tighten the #8 hardline connection at the condenser.**
10. Install the 3/8" Adel clamp onto the #6 condenser/drier hardline. Secure the Adel clamps together using a 10-24 x 1/2" pan head screw and a 10-24 nut with star washer (See Photo 8, below).

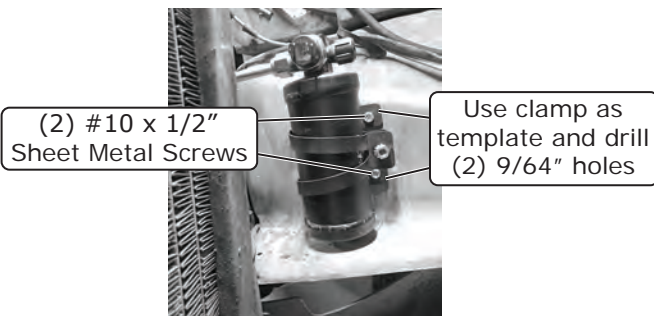

Photo 3



Photo 4

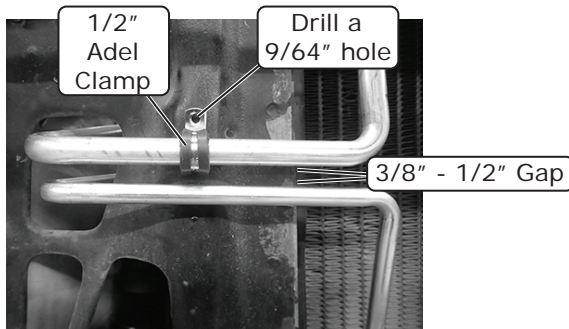

Photo 5

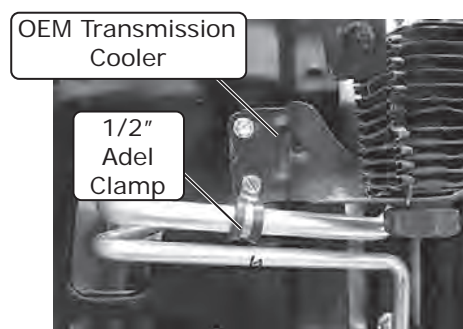

Photo 6

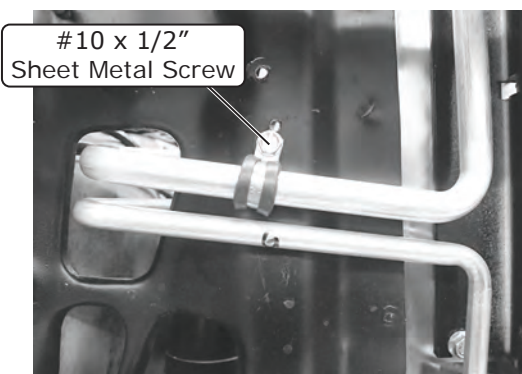

Photo 7

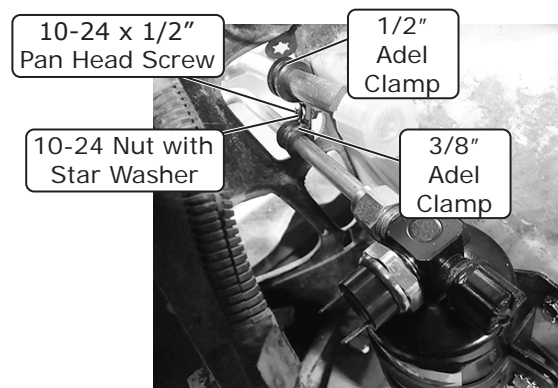

Photo 8



www.vintageair.com

Final Steps

1. At this point, finish securing the loosely set bolts for either radiator (Standard Core Support) or the condenser bracket (4x4 Core Support).
2. Ensure all hardline fittings are secured to Vintage Air's Standard Torque Specifications:
3. #6: 11 to 13 ft-lb.
4. #8: 15 to 20 ft-lb.
5. #10: 21 to 27 ft-lb.
6. Locate the 1/4-20 x 1/2" flange hex bolt. Reinstall the hood support latch and secure the middle lower latch brace with the flange hex bolt.
7. Reverse the process of disassembly for all essential remaining removed or disconnected parts. Reinstall parts from engine compartment and/or radiator accessories (If necessary).



www.vintageair.com

Packing List: Condenser Kit (011156)

O-rings/Refrigerant Oil

| | Qty | | Part No | Description |
|--|-----|--------------------------|-----------|--|
| | 1 | <input type="checkbox"/> | 071130 | Clamp, Drier |
| | 1 | <input type="checkbox"/> | 11079-VUS | Binary Switch, Male |
| | 4 | <input type="checkbox"/> | 18201-VUB | Spacer, 1/4" Length |
| | 3 | <input type="checkbox"/> | 18247-VUB | Screw, #10 x 1/2", Sheet Metal |
| | 8 | <input type="checkbox"/> | 182545 | Bolt, 10-24 x 1/2", Square-Neck Carriage |
| | 9 | <input type="checkbox"/> | 18260-VUB | Nut with Star Washer, 10-24 |
| | 1 | <input type="checkbox"/> | 182479 | Screw, 10-24 x 1/2", Pan Head |
| | 1 | <input type="checkbox"/> | 182870 | Bolt, 1/4-20 x 1/2", Flange Hex |
| | 8 | <input type="checkbox"/> | 18308-VUB | Bolt, 5/16-18 x 1", Hex |
| | 4 | <input type="checkbox"/> | 18312-VUB | Bolt, 5/16-18 x 1 3/4", Hex |
| <td>8</td> <td><input type="checkbox"/></td> <td>18610-VUB</td> <td>Lock Washer, 5/16"</td> | 8 | <input type="checkbox"/> | 18610-VUB | Lock Washer, 5/16" |
| | 8 | <input type="checkbox"/> | 18611-VUB | Washer, 5/16", Flat |
| <td>8</td> <td><input type="checkbox"/></td> <td>18977-VUB</td> <td>U-nut, 5/16"</td> | 8 | <input type="checkbox"/> | 18977-VUB | U-nut, 5/16" |
| | 1 | <input type="checkbox"/> | 18978-VUB | U-nut, 1/4-20 |
| | 1 | <input type="checkbox"/> | 23135-VUW | Compressor Lead |
| | 2 | <input type="checkbox"/> | 31600-VUD | Adel Clamp, 3/8" I.D. |
| | 2 | <input type="checkbox"/> | 31603-VUD | Adel Clamp, 1/2" I.D. |
| <td>4</td> <td><input type="checkbox"/></td> <td>65976-VUE</td> <td>Push-on Ring, 3/16"</td> | 4 | <input type="checkbox"/> | 65976-VUE | Push-on Ring, 3/16" |

Packed By: _____

| | Qty | | Part No | Description |
|--|-----|--------------------------|-----------|-----------------|
| | 4 | <input type="checkbox"/> | 33857-VUF | O-ring, #6 |
| | 3 | <input type="checkbox"/> | 33858-VUF | O-ring, #8 |
| | 1 | <input type="checkbox"/> | 41117-VUP | Refrigerant Oil |

Packed By: _____

Brackets

| | Qty | | Part No | Description |
|--|-----|--------------------------|---------|------------------------------------|
| | 1 | <input type="checkbox"/> | 647191 | Bracket, Condenser, Driver-Side |
| | 1 | <input type="checkbox"/> | 647193 | Bracket, Condenser, Passenger-Side |

Packed By: _____

Hardlines

| | Qty | | Part No | Description |
|--|-----|--------------------------|---------|----------------------------------|
| | 1 | <input type="checkbox"/> | 082076 | Hardline#6, Condenser/Drier |
| | 1 | <input type="checkbox"/> | 082077 | Hardline#6, Condenser/Compressor |

Packed By: _____

Condenser/Drier

| | Qty | | Part No | Description |
|--|-----|--------------------------|-----------|-------------------------------------|
| | 1 | <input type="checkbox"/> | 037035 | Condenser, 14" x 25", Parallel Flow |
| | 1 | <input type="checkbox"/> | 07321-VUC | Drier |

Packed By: _____

Inspected By: _____
Date: _____

**NOTE: Images may not depict actual parts and quantities.
Refer to packing list for actual parts and quantities.**