

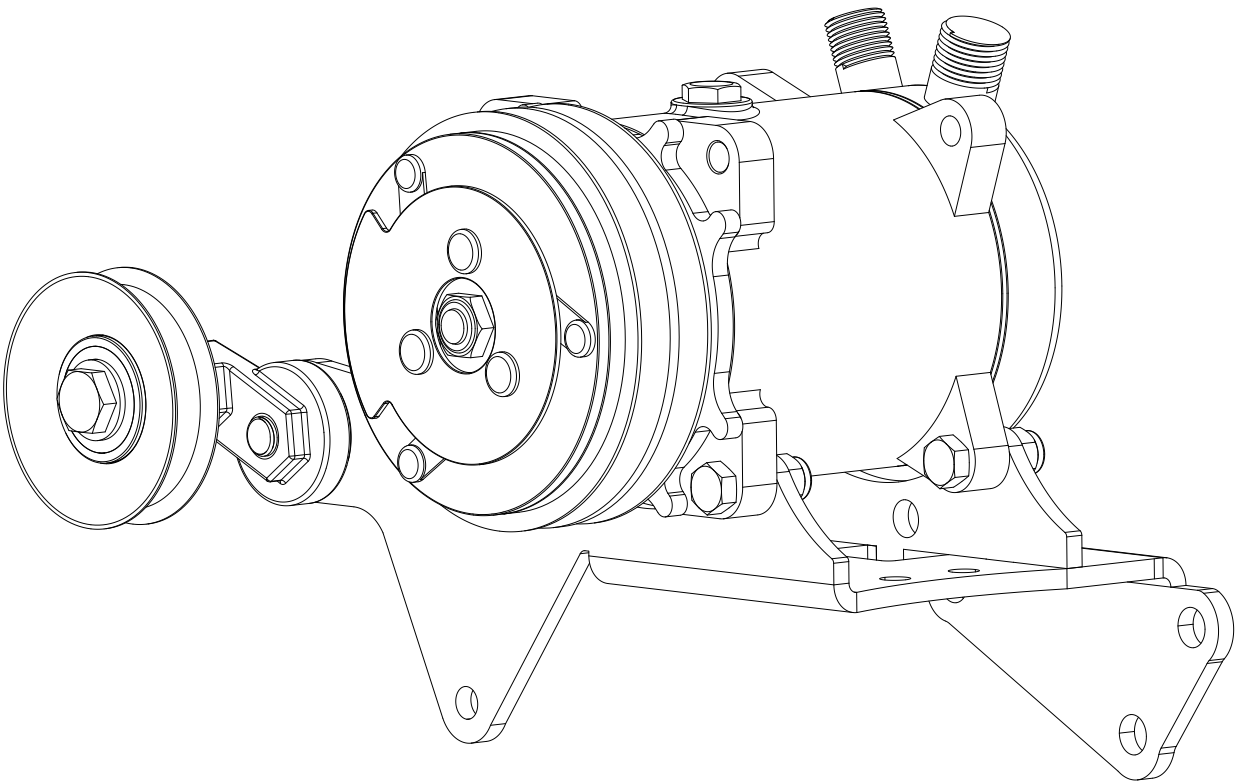

an ISO 9001:2015 Registered Company

351M/400

Compressor Bracket Kit (137000)



18865 Goll St. San Antonio, TX 78266
Phone: 800-862-6658
Sales: sales@vintageair.com
Tech Support: tech@vintageair.com
www.vintageair.com



www.vintageair.com

Table of Contents

Cover..... 1

Table of Contents/Preliminary Information..... 2

Packing List/Parts Disclaimer..... 3

Important Notice..... 4

Compressor and Bracket Disassembly..... 5

Idler Arm Assembly..... 6

Compressor Bracket Installation (with OEM Power Steering)..... 7

Compressor Bracket Installation (without Power Steering)..... 8

Compressor Installation..... 9

Belt Routing Diagram..... 10

Packing List..... 11

Additional Info: Please Read Before Beginning

- The compressor and alternator ground through the bracket and into the engine, therefore it's important to have a good ground connection. A separate ground wire may also be run to ensure ground continuity.
- This kit is designed to work with or without the OEM power steering bracket.
- All vehicles used in the development of this kit were equipped with power steering. If your vehicle does not have power steering, your pulleys and routing may differ from our belt routing diagrams.
- This kit requires a 3-groove crank pulley.
- Some engines equipped with a dealer-installed A/C or T/E (smog pumps) may have a 4-groove pulley and additional idlers, routing may vary.
- Due to the wide range of accessory options and pulley diameters, you will need to measure your pulleys to get the proper length V-belts.
- **Vintage Air's Ford Bronco and Ford F-Series Surefit system requires a minimum 60-amp alternator. While the OEM 60-amp alternator will work with the Surefit system, additional accessories may require a larger alternator. The Surefit system draws approximately 15 amps, and without the sufficient amperage, the A/C system or other accessories may not function properly.**



A detailed tech video outlining the installation process is available on Vintage Air's YouTube channel at <https://bit.ly/3haQQh>. Viewing the tech video along with the written instructions will provide the installer the most detailed installation procedure.



Packing List:

Compressor Bracket Kit (137000)

www.vintageair.com

No.	Qty.	Part No.	Description
1.	1	136999	Bracket, Compressor
2.	1	191102	Hardware Kit

**** Before beginning installation, open all packages and check contents of shipment. Please report any shortages directly to Vintage Air within 15 days. After 15 days, Vintage Air will not be responsible for missing or damaged items.**

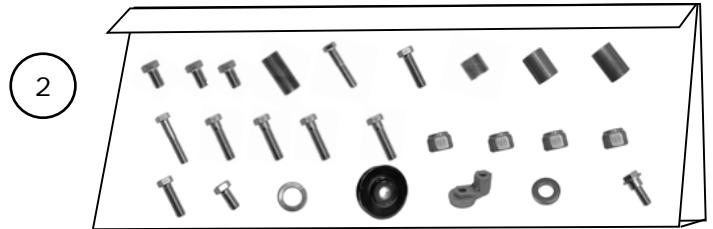
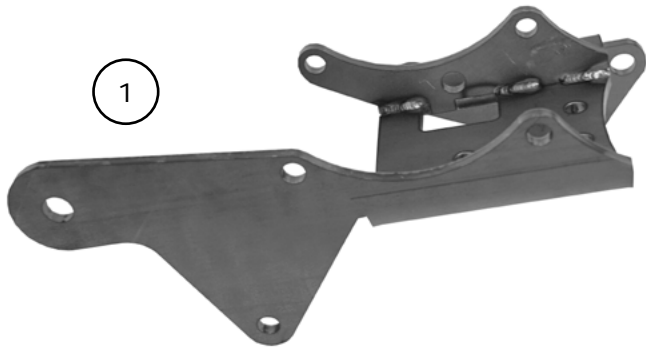

NOTE: Images may not depict actual parts and quantities. Refer to packing list for actual parts and quantities.



www.vintageair.com

Important Notice—Please Read

For Maximum System Performance, Vintage Air Recommends the Following:

NOTE: Vintage Air systems are designed to operate with R134a refrigerant only. Use of any other refrigerant could damage your A/C system and/or vehicle, and possibly cause a fire, in addition to potentially voiding the warranties of the A/C system and its components.

Refrigerant Capacities:

Vintage Air System: 1.8 lbs. (28.8 oz.) or 816 grams of **R134a**, charged by weight with a quality charging station or scale. **NOTE: Use of the proper type and amount of refrigerant is critical to system operation and performance.**

Other Systems: Consult manufacturer's guidelines.

Lubricant Capacities:

New Vintage Air-Supplied Sanden Compressor: No additional oil needed (Compressor is shipped with proper oil charge).

All Other Compressors: Consult manufacturer (Some compressors are shipped dry and will need oil added).

Safety Switches

Your Vintage Air system is equipped with a binary pressure safety switch. A binary switch disengages the compressor clutch in cases of extreme low pressure conditions (refrigerant loss) or excessively high head pressure (406 PSI) to prevent compressor damage or hose rupture. A trinary switch combines Hi/Lo pressure protection with an electric fan operation signal at 254 PSI, and should be substituted for use with electric fans. Compressor safety switches are extremely important since an A/C system relies on refrigerant to circulate lubricant.

Service Info:

Protect Your Investment: Prior to assembly, it is critical that the compressor, evaporator, A/C hoses and fittings, hardlines, condenser and receiver/drier remain capped. Removing caps prior to assembly will allow moisture, insects and debris into the components, possibly leading to reduced performance and/or premature failure of your A/C system. This is especially important with the receiver/drier.

Additionally, when caps are removed for assembly, **BE CAREFUL!** Some components are shipped under pressure with dry nitrogen.

Evacuate the System for 35-45 Minutes: Ensure that system components (Drier, compressor, evaporator and condenser) are at a temperature of at least 85°F. On a cool day, the components can be heated with a heat gun **or** by running the engine with the heater on before evacuating. Leak check and charge to specifications.

Bolts Passing Through Cowl and/or Firewall:

To ensure a watertight seal between the passenger compartment and the vehicle exterior, for all bolts passing through the cowl and/or firewall, Vintage Air recommends coating the threads with silicone prior to installation.

Heater Hose (not included with this kit):

Heater hose may be purchased from Vintage Air (Part#31800-VUD) or your local parts retailer. Routing and required length will vary based on installer preference.

Compressor and Bracket Disassembly

NOTE: Vehicles without factory air will only follow Steps 2 and 8, below.

1. Evacuate the A/C system.
2. Disconnect the battery.
3. Remove the hoses from the A/C compressor (See Photo 1, below).
4. Loosen the A/C belt tensioner and remove the belt (See Photo 1, below).
5. Loosen the (4) bolts on the power steering and release the tension on the belt (See Photo 1, below).
6. Remove the tensioner bracket by removing (5) bolts.
7. Remove the OEM compressor from the main bracket by removing the (4) bolts (See Photo 1, below).
8. Remove the upper left and right bolts from the power steering bracket, then swing the bracket and pump down (See Photos 2 & 3, below). **NOTE: This allows full access to the main bracket bolts.**
9. Remove the compressor bracket by removing the (4) mounting bolts (See Photos 3 & 4, below).

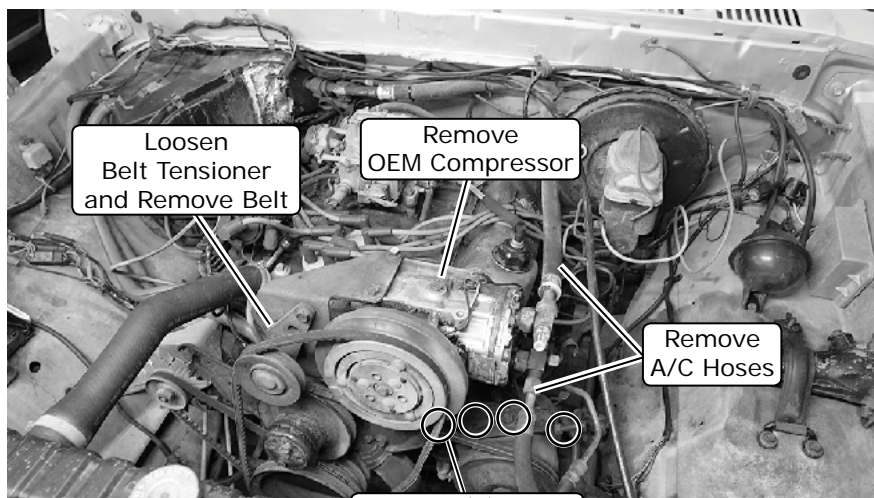

Loosen (4) Bolts on Power Steering

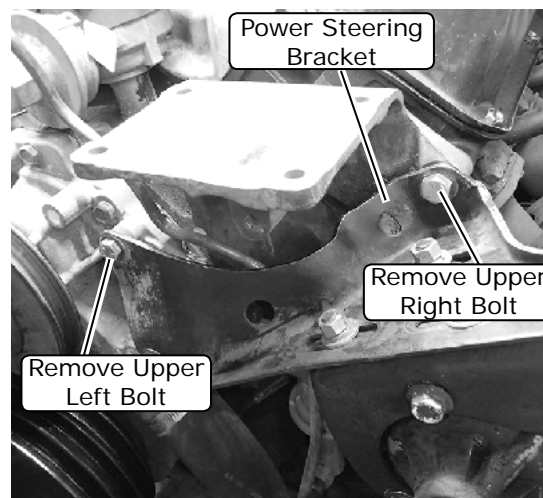

Photo 2

Photo 1

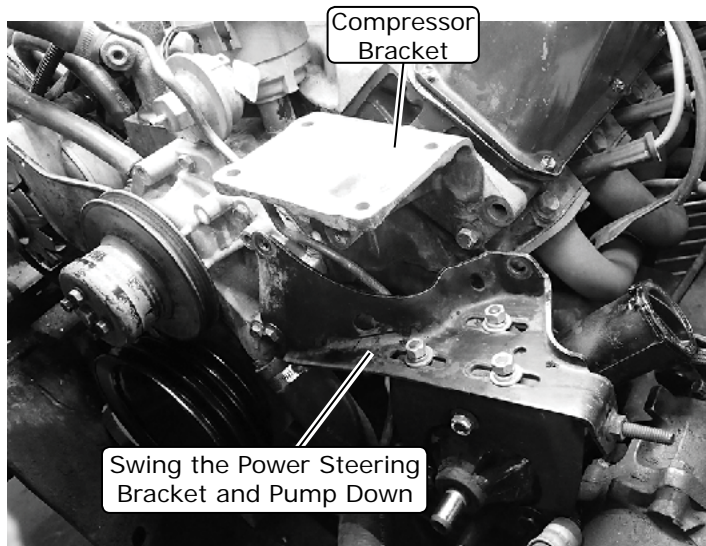

Photo 3

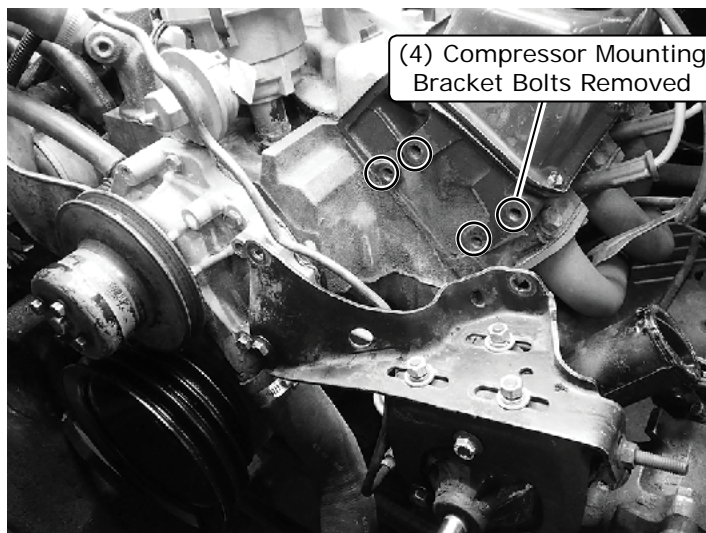
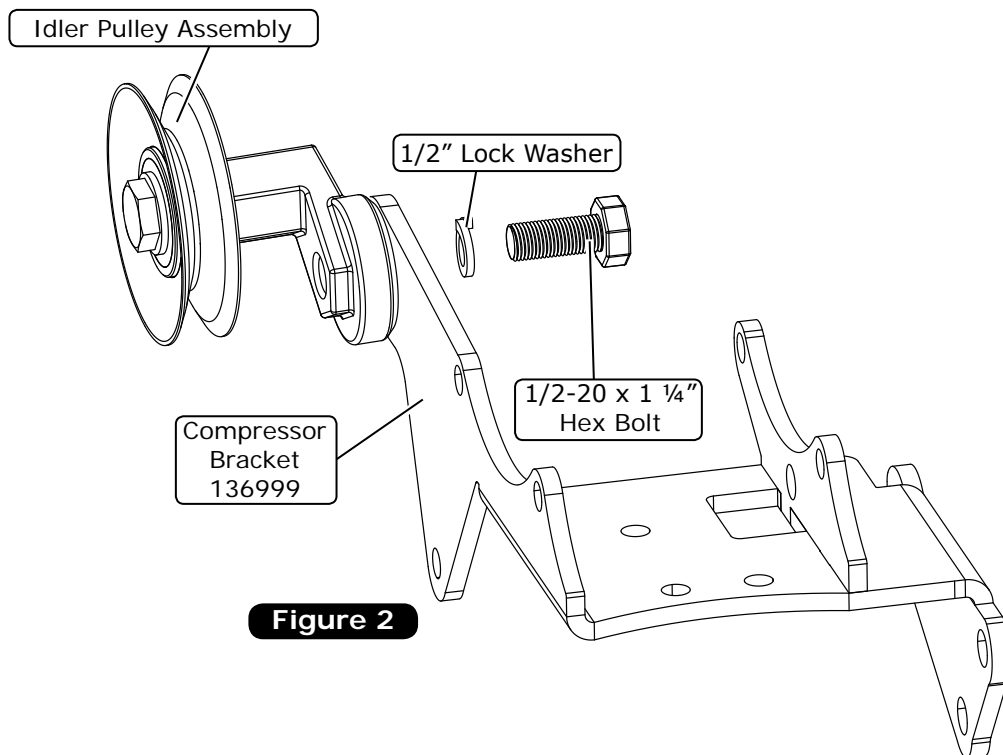
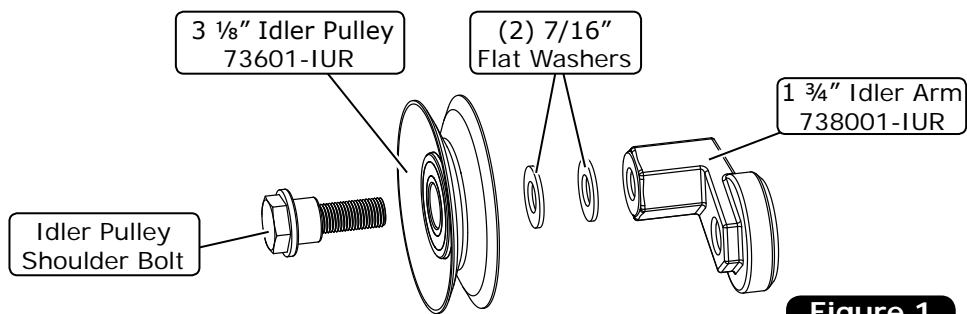

Photo 4

Idler Arm Assembly

1. Assemble the idler pulley onto the idler arm using the idler pulley shoulder bolt, 3 1/8" idler pulley, (2) 7/16" flat washers and the 1 3/4" idler arm (See Figure 1, below).
2. Attach the assembled idler pulley onto the compressor bracket using a 1/2-20 x 1 1/4" hex bolt and 1/2" lock washer (See Figure 2, below).



Compressor Bracket Installation (with OEM Power Steering)

www.vintageair.com

1. Place the compressor bracket flat against the engine head and secure it using (2) 7/16-14 x 3/4" hex bolts on the lower head mount locations (See Photo 1, below).
2. Secure the upper mount using a 7/16-14 x 2 1/4" hex bolt through the compressor bracket and a .750" OD x .469" ID x 1.695" length spacer on the upper mount (See Photo 2, below).
3. Temporarily thread the 7/16-14 x 2 1/4" hex bolt into the far right boss to ensure the bracket alignment, then tighten the lower bolt head (See Photo 3, below).
4. Remove the 7/16-14 x 2 1/4" hex bolt from the far right boss (See Photo 3, below).
5. Swing the power steering bracket back up into place and reinstall the 7/16-14 x 1 1/2" hex bolt with a .750" OD x .469" ID x .695" length spacer (See Photo 4, below).
6. Thread a 3/8-16 x 2" hex bolt through the compressor bracket and .750" OD x .406" ID x .990" length spacer and into the water pump (See Photo 5, below). **NOTE: This kit includes an optional 3/8-16 bolt to replace the lower power steering pump bolt.**
7. Tighten all bolts (See Photo 6, below).

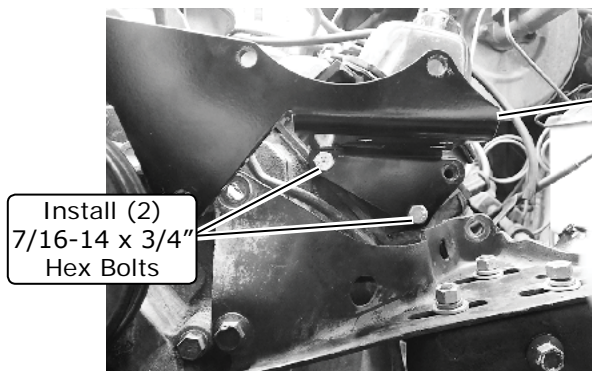

Install (2)
 7/16-14 x 3/4"
 Hex Bolts

Compressor
 Bracket
 136999

Photo 1

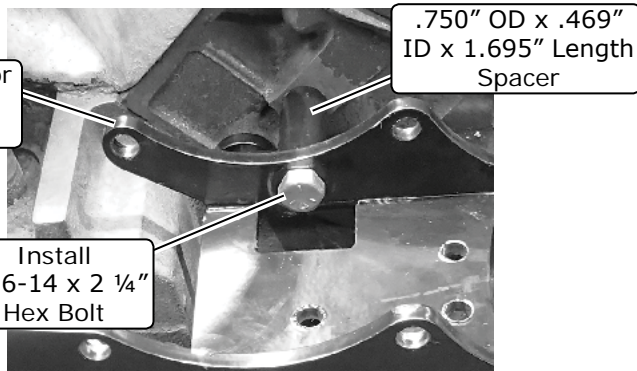

.750" OD x .469"
 ID x 1.695" Length
 Spacer

Install
 7/16-14 x 2 1/4"
 Hex Bolt

Photo 2

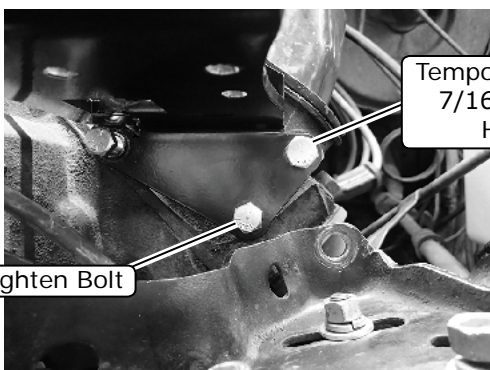

Temporarily Thread
 7/16-14 x 2 1/4"
 Hex Bolt

Tighten Bolt

Photo 3

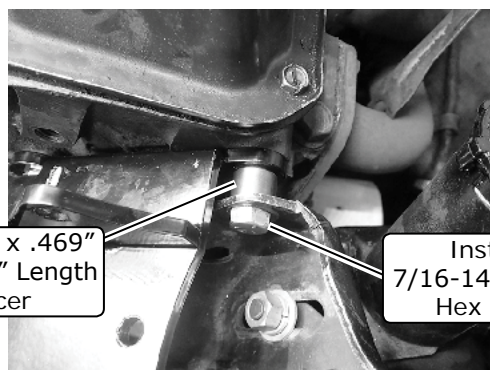

.750" OD x .469"
 ID x .695" Length
 Spacer

Install
 7/16-14 x 1 1/2"
 Hex Bolt

Photo 4

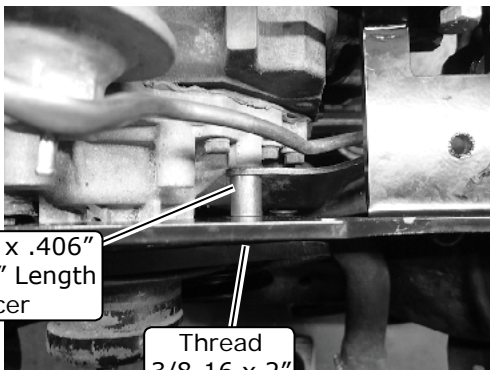

.750" OD x .406"
 ID x .990" Length
 Spacer

Thread
 3/8-16 x 2"
 Hex Bolt

Photo 5

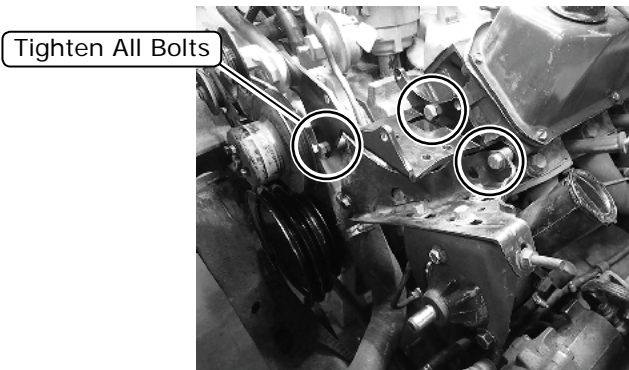

Tighten All Bolts

Photo 6

Compressor Bracket Installation (without Power Steering)

1. Place the compressor bracket flat against the engine head and secure it using (3) 7/16-14 x 3/4" hex bolts on the lower head mount locations (See Photo 1, below).
2. Secure the upper mount using a 7/16-14 x 2 1/4" hex bolt through the compressor bracket and a .750" OD x .469" ID x 1.695" length spacer on the upper mount (See Photo 2, below).
3. Thread a 3/8-16 x 2" hex bolt through the compressor bracket and .750" OD x .406" ID x 1.125" length spacer into the water pump (See Photo 3, below).
4. Once the compressor bracket is in place, tighten all the mounting bolts (See Photo 4, below).

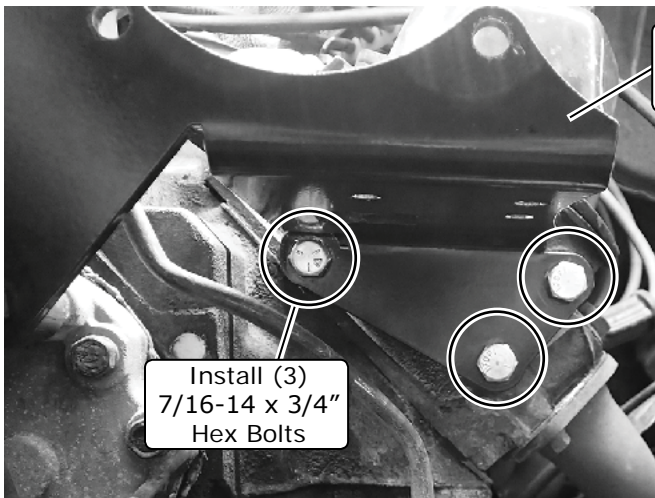

Photo 1

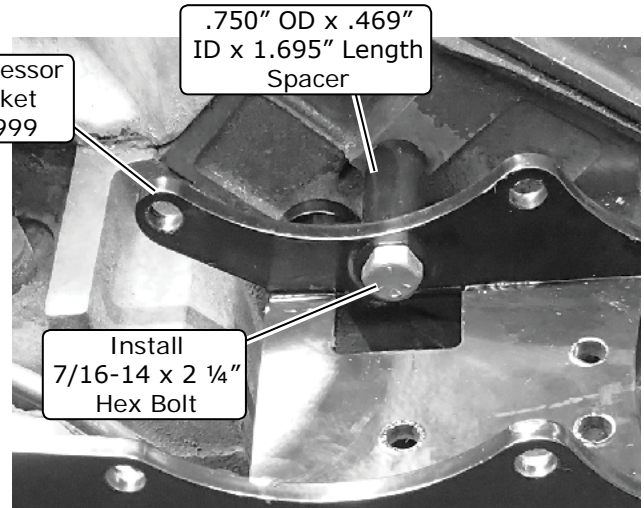

Photo 2

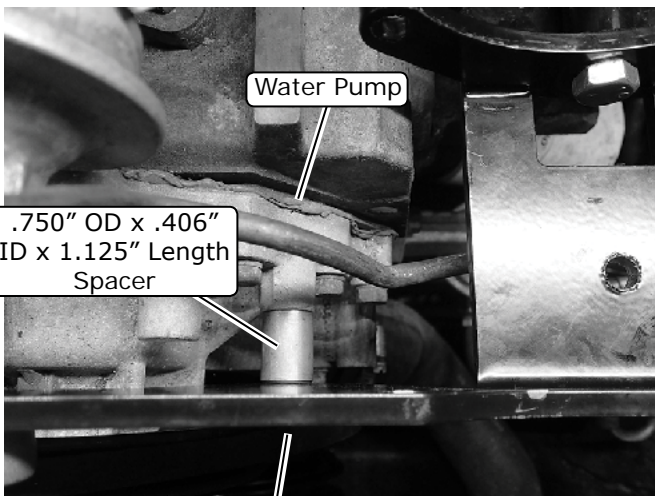

Photo 3

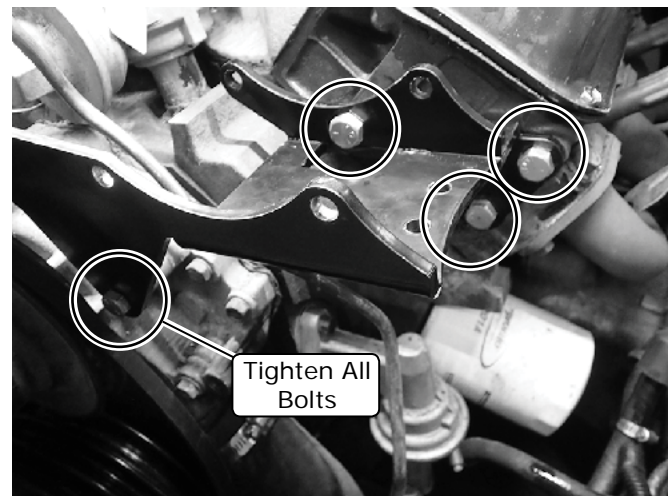
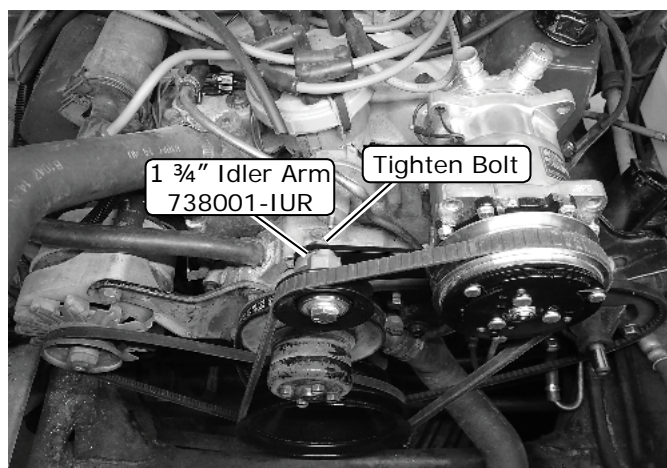
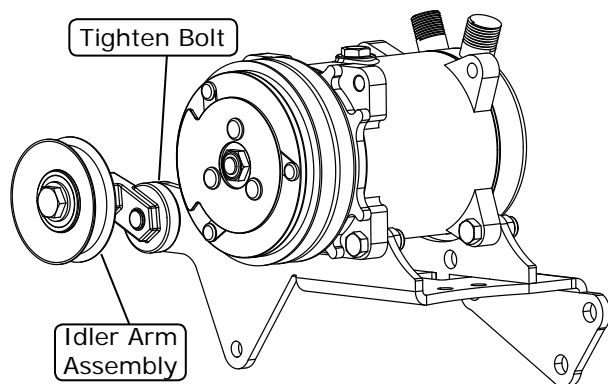
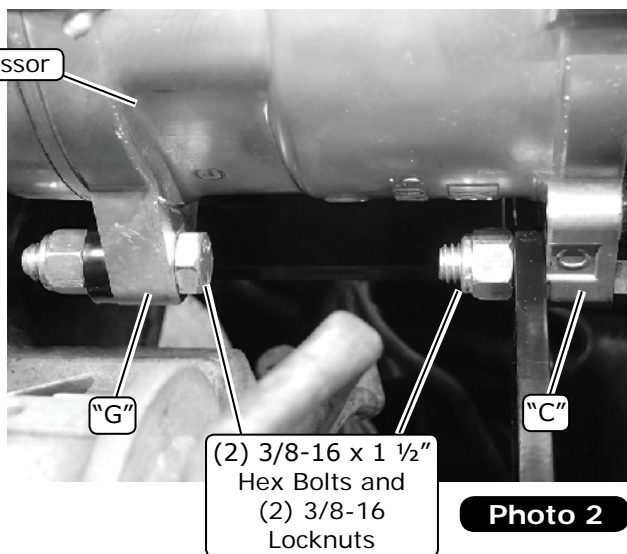
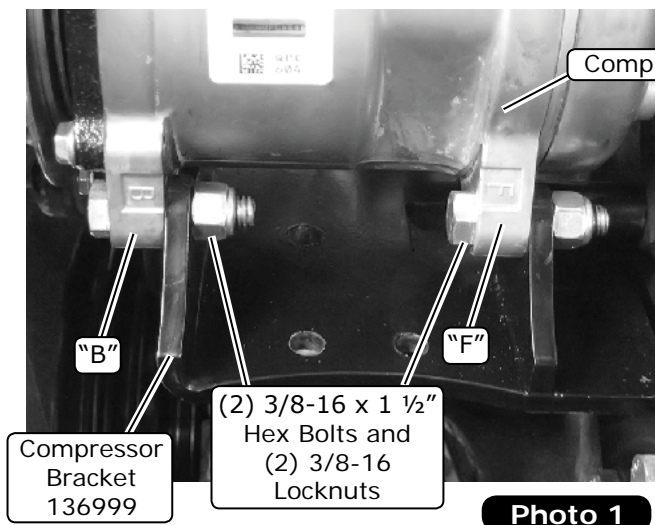

Photo 4

Compressor Installation

- Place the compressor onto the bracket with tabs "B," "C," "F" and "G" aligning to the front of the bracket as shown in Photos 1 and 2, below. Secure the compressor using (4) 3/8-16 x 1 1/2" hex bolts and (4) 3/8-16 locknuts through all (4) lower compressor tabs. **NOTE: Vintage Air recommends using only Dayco, Gates or Goodyear brand reinforced V-belts with this compressor bracket kit. A compressor belt length of 52 7/8" was used. However, belt lengths may vary depending on the accessories present and the diameter of the water pump, crankshaft, alternator and power steering pulleys.**
- Tension the idler arm using a 1" wrench, and tighten the rear bolt with a 3/4" wrench (See Figure 1 and Photo 3, below).



Belt Routing Diagram

NOTE: Smog pump application not shown on belt routing diagrams.

with Power Steering

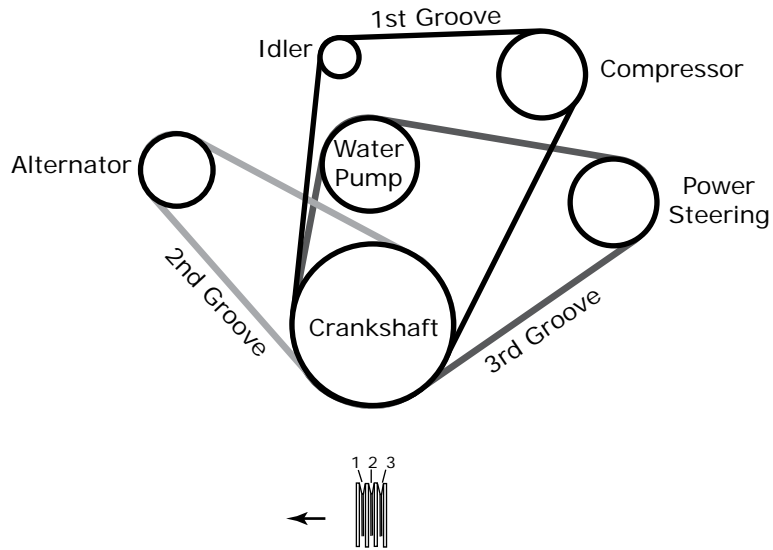

Crankshaft Pulley Grooves:

1. Crankshaft, Idler & Compressor
2. Crankshaft, Alternator
3. Crankshaft, Water Pump & Power Steering

without Power Steering

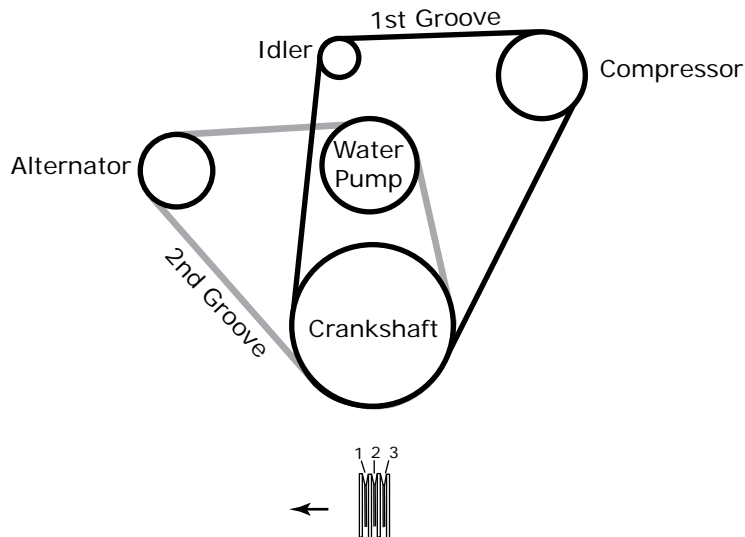

Crankshaft Pulley Grooves:

1. Crankshaft, Idler & Compressor
2. Crankshaft, Alternator & Water Pump
3. N/A



www.vintageair.com

Packing List: Compressor Bracket Kit (137000)

No.	Qty.	Part No.	Description
1.	1	136999	Bracket, Compressor
2.	1	191102	Hardware Kit

Checked By: _____
 Packed By: _____
 Date: _____

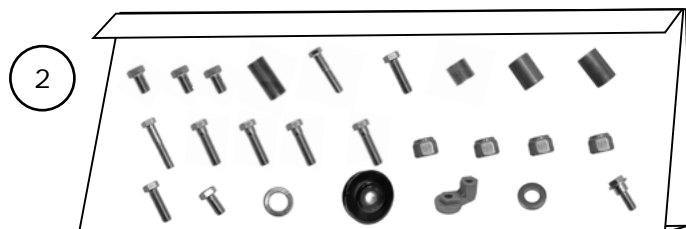

**NOTE: Images may not depict actual parts and quantities.
 Refer to packing list for actual parts and quantities.**