



1970-74 Challenger/Cuda

with Factory Air

Rallye Dash Control Panel Conversion Kit

471076-EDA

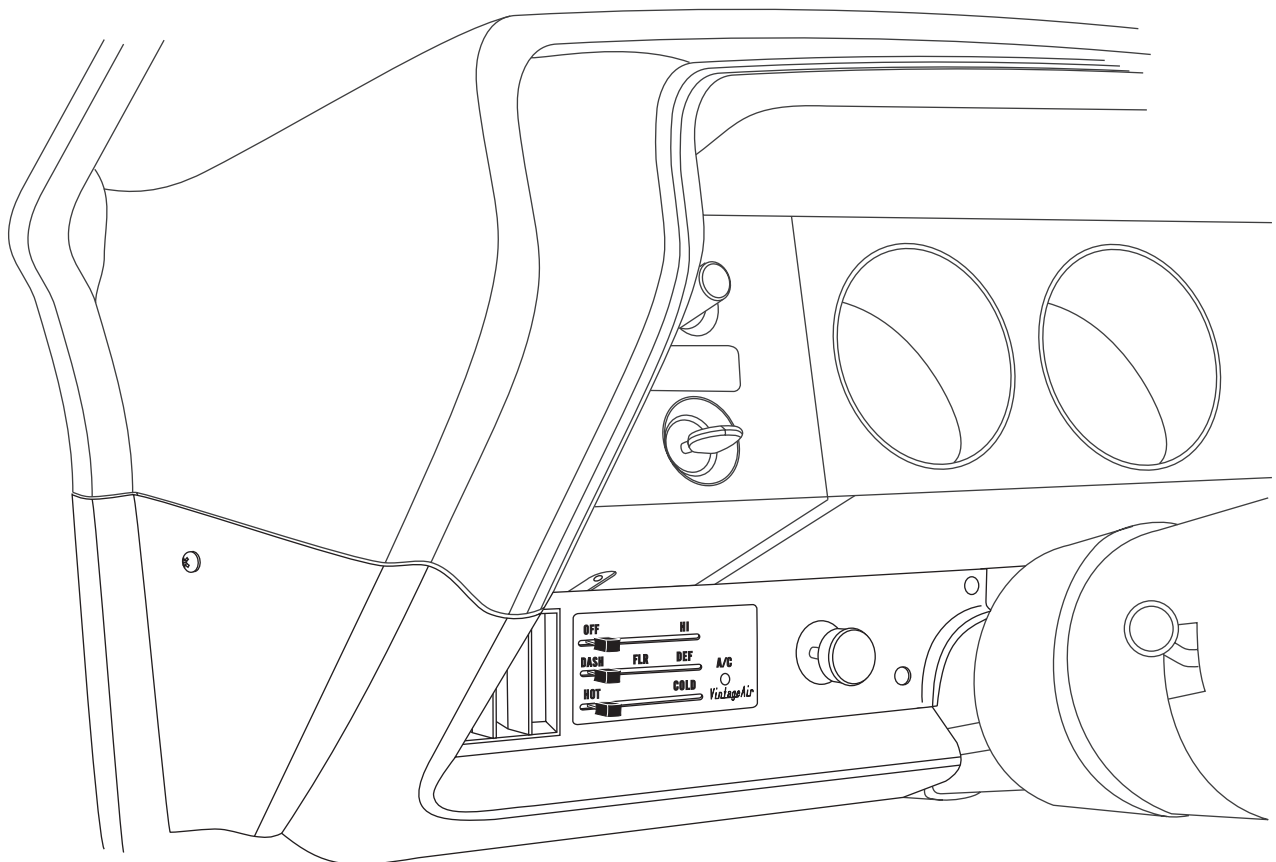

18865 Goll St. San Antonio, TX 78266

Phone: 800-862-6658

Sales: sales@vintageair.com

Tech Support: tech@vintageair.com

www.vintageair.com



www.vintageair.com

Table of Contents

Cover.....	1
Table of Contents.....	2
Packing List/Parts Disclaimer.....	3
OEM Control Panel Removal.....	4
Control Panel Installation.....	5
Knob Installation, Control Panel Harness Installation.....	6
Gen IV Wiring Diagram.....	7
Gen 5 Wiring Diagram.....	8
Operation of Controls.....	9
Packing List.....	10



www.vintageair.com

Packing List: Control Panel Kit (471076-EDA)

No.	Qty.	Part No.	Description
1.	1	471073-EDA	Rallye Dash Control Panel Assembly
2.	2	18235-VUB	Screw, #8 x 1/2", Pan Head
3.	2	186008-WSR	Washer, #8
4.	3	491006-KUR	Knob, Slide POT
5.	1	232007-VUR	Control Harness, Gen IV/5 Universal

**** Before beginning installation, open all packages and check contents of shipment. Please report any shortages directly to Vintage Air within 15 days. After 15 days, Vintage Air will not be responsible for missing or damaged items.**

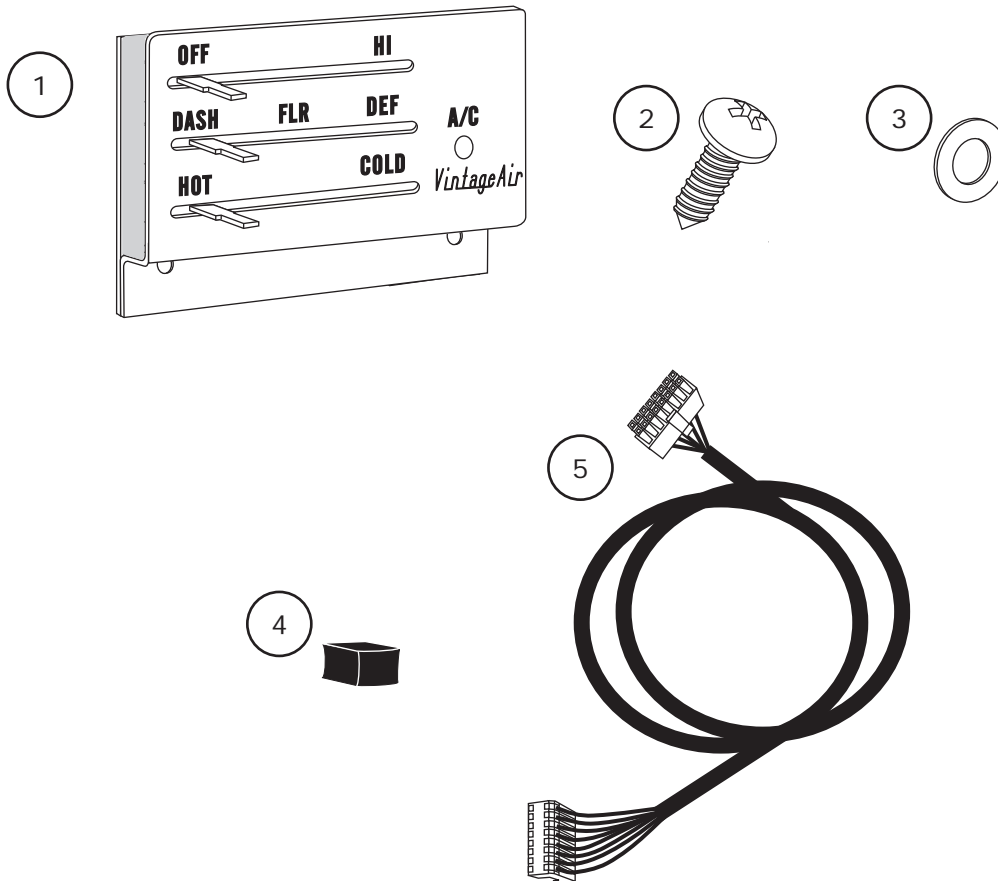

**NOTE: Images may not depict actual parts and quantities.
Refer to packing list for actual parts and quantities.**



www.vintageair.com

OEM Control Panel Removal

Perform the following:

1. Disconnect the wires, vacuum hoses and control lever cable from the back of the OEM control panel. **NOTE: When using a Vintage Air supplied control panel, connect the 20 AWG tan wire from the Gen IV wiring harness (232010) or Gen 5 wiring harness (231505) to the factory dash lights to enable panel backlighting.**
2. Remove the OEM control panel (discard) (See Figure 1, below).

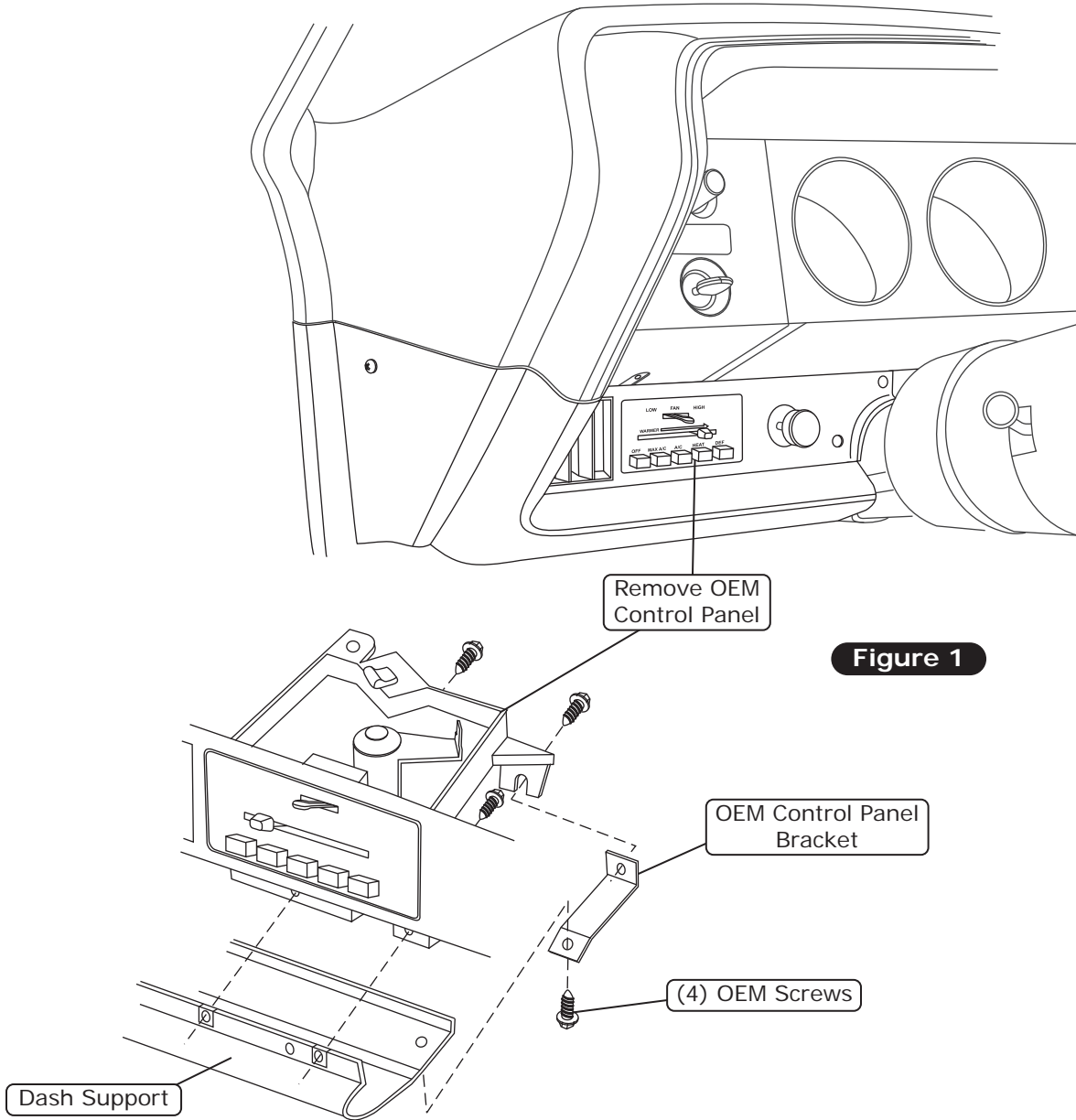

Figure 1



www.vintageair.com

Control Panel Installation

1. Install the control panel assembly from under the dash into the opening of the OEM control panel bezel as shown in Figure 1, below.
2. Secure the control panel assembly to the dash using (2) #8 x 1/2" pan head screws as shown in Figure 1, below.

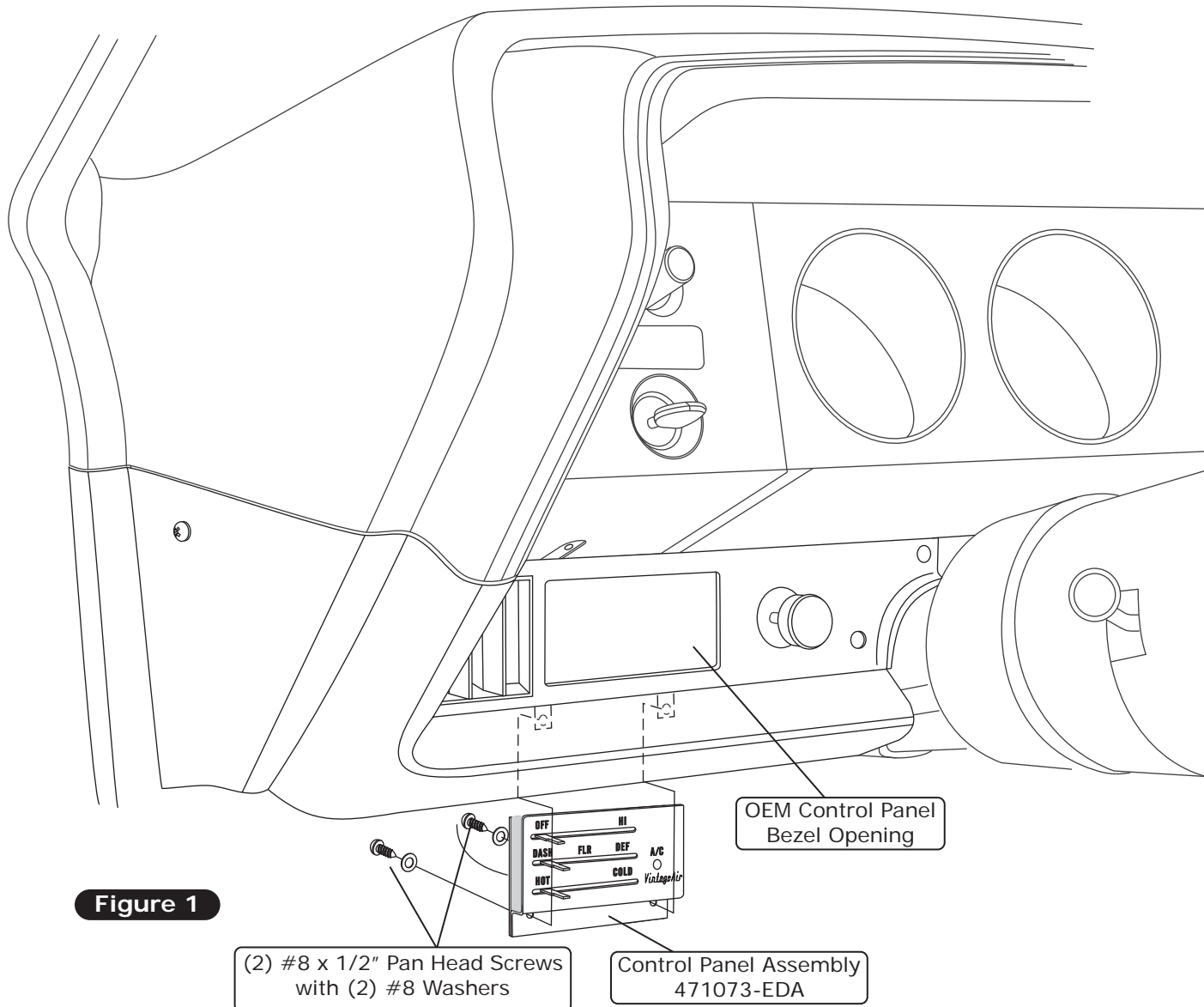



www.vintageair.com

Knob Installation

1. Install the (3) knobs as shown in Figure 1, below.

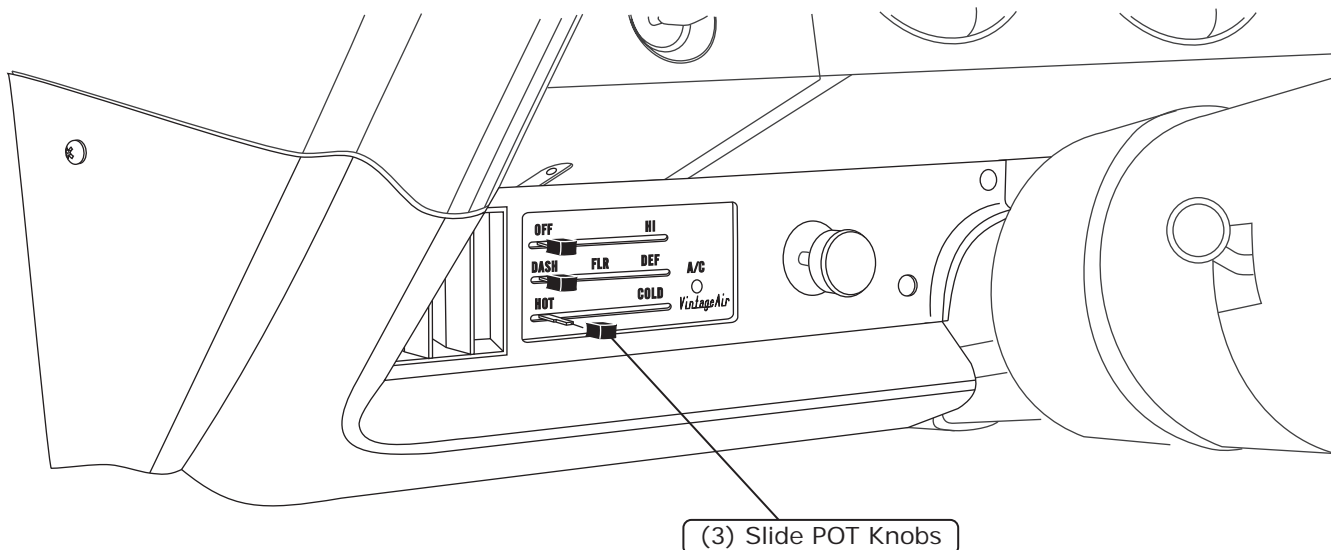

Figure 1

Control Panel Harness Installation

1. From under the dash, plug in the control panel wiring harness as shown in Figure 1, below.

NOTE: When using a Vintage Air supplied control panel, connect the 20 AWG tan wire from the Gen IV wiring harness (232010) or Gen 5 wiring harness (231505) to the factory dash lights to enable panel backlighting.

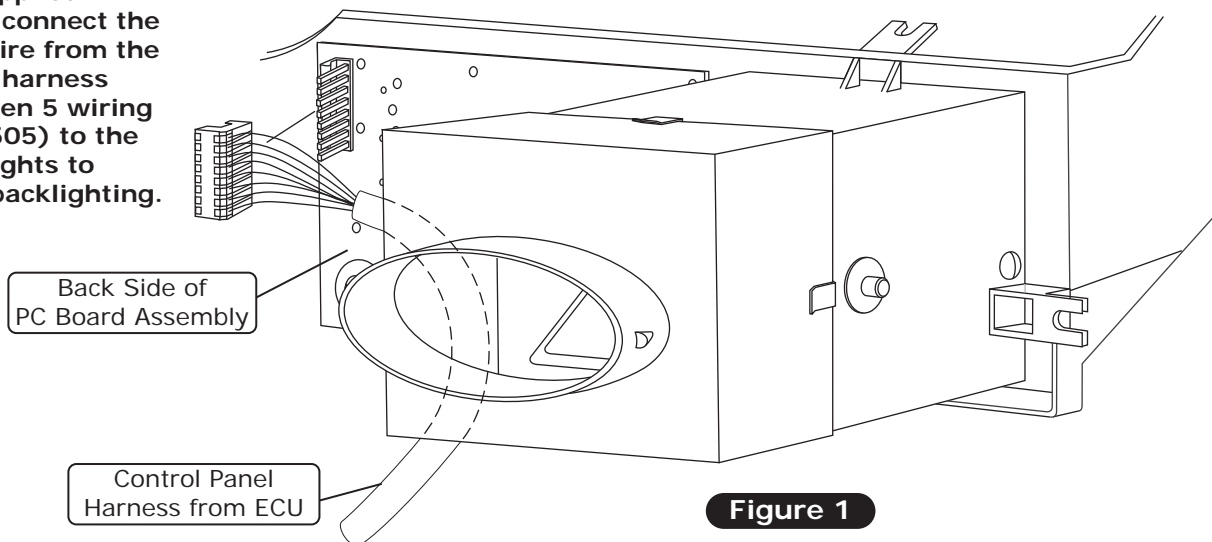

Figure 1



www.vintageair.com

Gen IV Wiring Diagram

232007-VUR

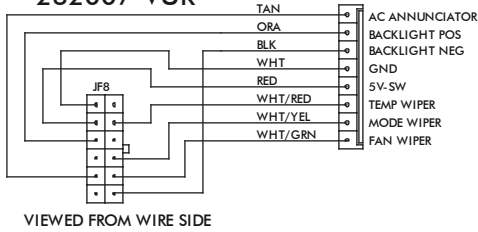

VIEWED FROM WIRE SIDE

232002-VUA

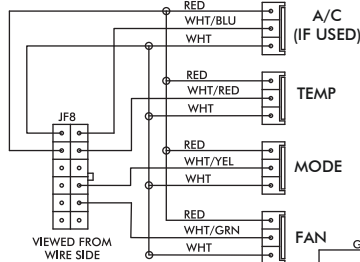

VIEWED FROM WIRE SIDE

PROGRAM

N/A

* DASH LAMP (IF USED)

*** WIDE OPEN THROTTLE SWITCH (OPTIONAL)

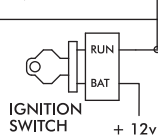

IGNITION SWITCH + 12v

GEN IV ECU

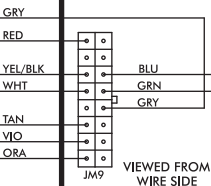

VIEWED FROM WIRE SIDE

PRE-WIRED

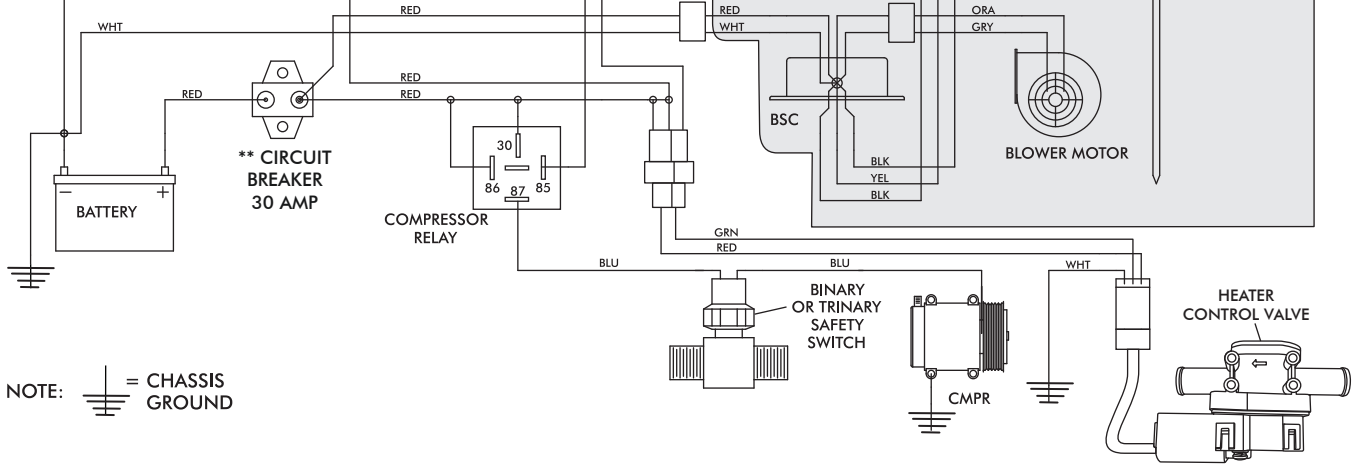
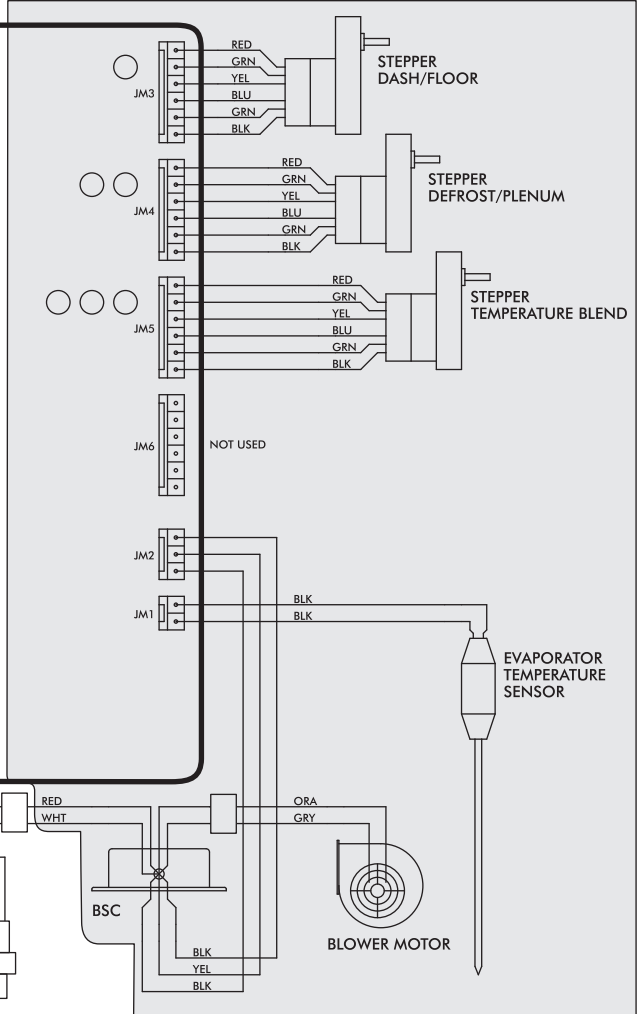

NOTE: = CHASSIS GROUND

- * Dash lamp is used only with type 232007-VUR harness.
- ** Warning: Always mount circuit breaker as close to the battery as possible. (NOTE: Wire between battery and circuit breaker is unprotected and should be carefully routed to avoid a short circuit).
- *** Wide open throttle switch contacts close only at full throttle, which disables A/C compressor.



www.vintageair.com

Gen 5 Wiring Diagram

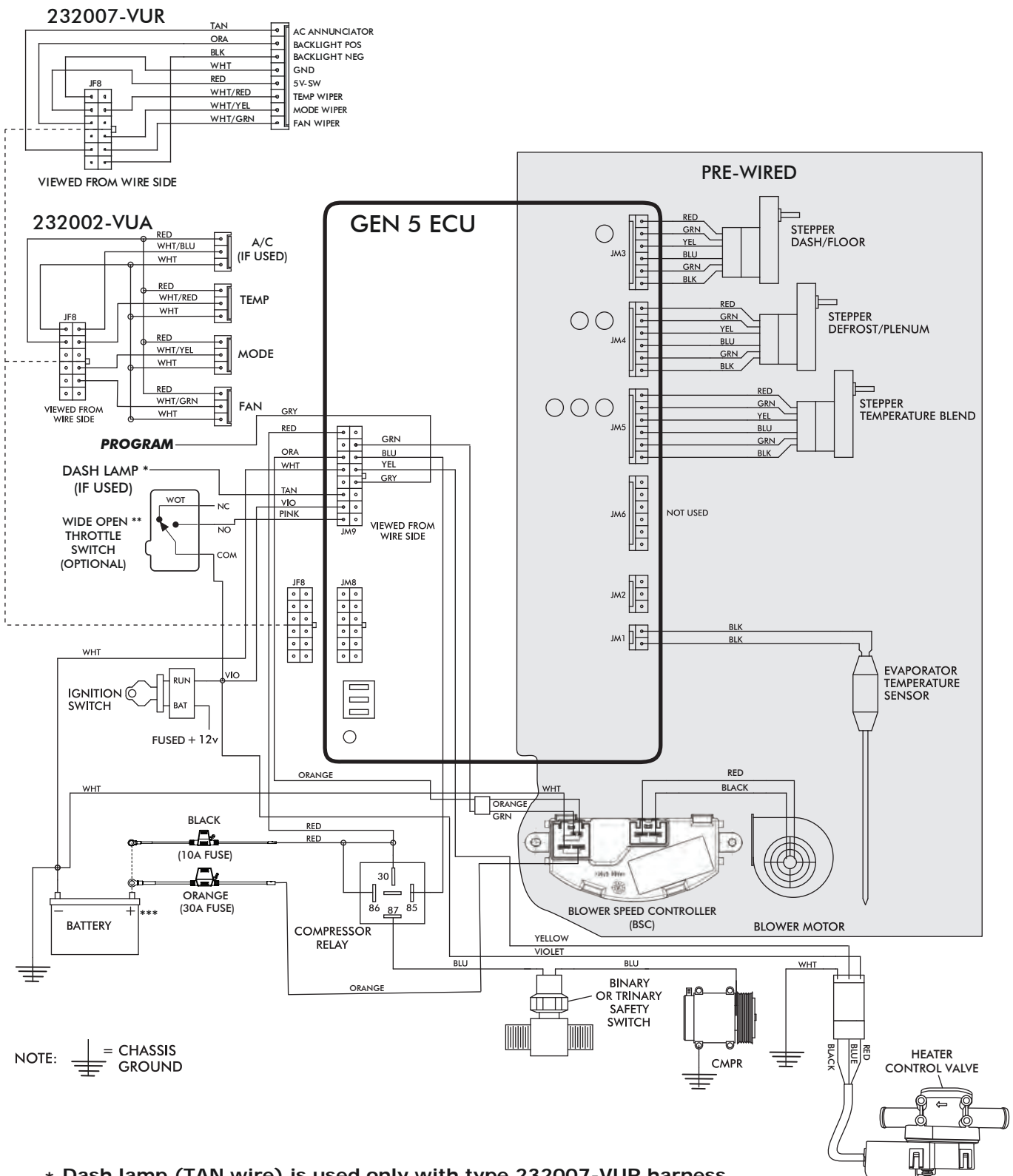

* Dash lamp (TAN wire) is used only with type 232007-VUR harness.

** Wide open throttle switch contacts close only at full throttle, which disables A/C compressor.

*** Install fuse assemblies at or as near to the battery as possible.



www.vintageair.com

Operation of Controls

On Gen IV or Gen 5 systems with three lever/knob controls, the temperature control toggles between heat and A/C operations. To activate A/C, move the temperature lever/knob all the way to cold and then back it off to the desired vent temperature. For heat operation, move the temperature lever/knob all the way to hot and then adjust to the desired vent temperature. The blower will momentarily change speed, each time you toggle in and out of heat and A/C operations, to indicate the change.

Blower Speed

This lever/knob controls blower speed, from OFF to HI.

Mode Control

This lever/knob controls the mode positions, from DASH to FLOOR to DEFROST, with a blend in between.

Temperature Control

This lever/knob controls the temperature, from HOT to COLD.

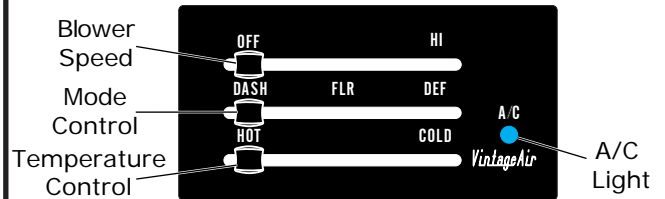

A/C Operation

Blower Speed

Adjust to desired speed.

Mode Control

Adjust to desired mode position (DASH position recommended).

Temperature Control

For A/C operation, adjust to coldest position to engage compressor (Adjust between HOT and COLD to reach desired temperature).

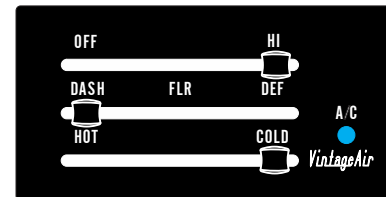

NOTE: A/C operation toggles on & off when thermostat lever is moved to the HOT or COLD ends of travel. A/C mode is indicated by the blue A/C light.

Heat Operation

Blower Speed

Adjust to desired speed.

Mode Control

Adjust to desired mode position (FLOOR position recommended).

Temperature Control

For maximum heating, adjust to hottest position (Adjust between HOT and COLD to reach desired temperature).

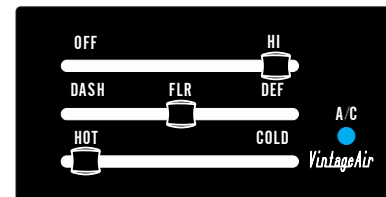

Defrost/De-fog Operation

Blower Speed

Adjust to desired speed.

Temperature Control

Adjust to desired temperature.

Mode Control

Adjust to DEFROST position for maximum defrost, or between FLOOR and DEFROST positions for a bi-level blend (Compressor is automatically engaged).





www.vintageair.com

Packing List: Control Panel Kit (471076-EDA)

No.	Qty.	Part No.	Description
1.	1	471073-EDA	Rallye Dash Control Panel Assembly
2.	2	18235-VUB	Screw, #8 x 1/2", Pan Head
3.	2	186008-WSR	Washer, #8
4.	3	491006-KUR	Knob, Slide POT
5.	1	232007-VUR	Control Harness, Gen IV/5 Universal

Checked By: _____
Packed By: _____
Date: _____

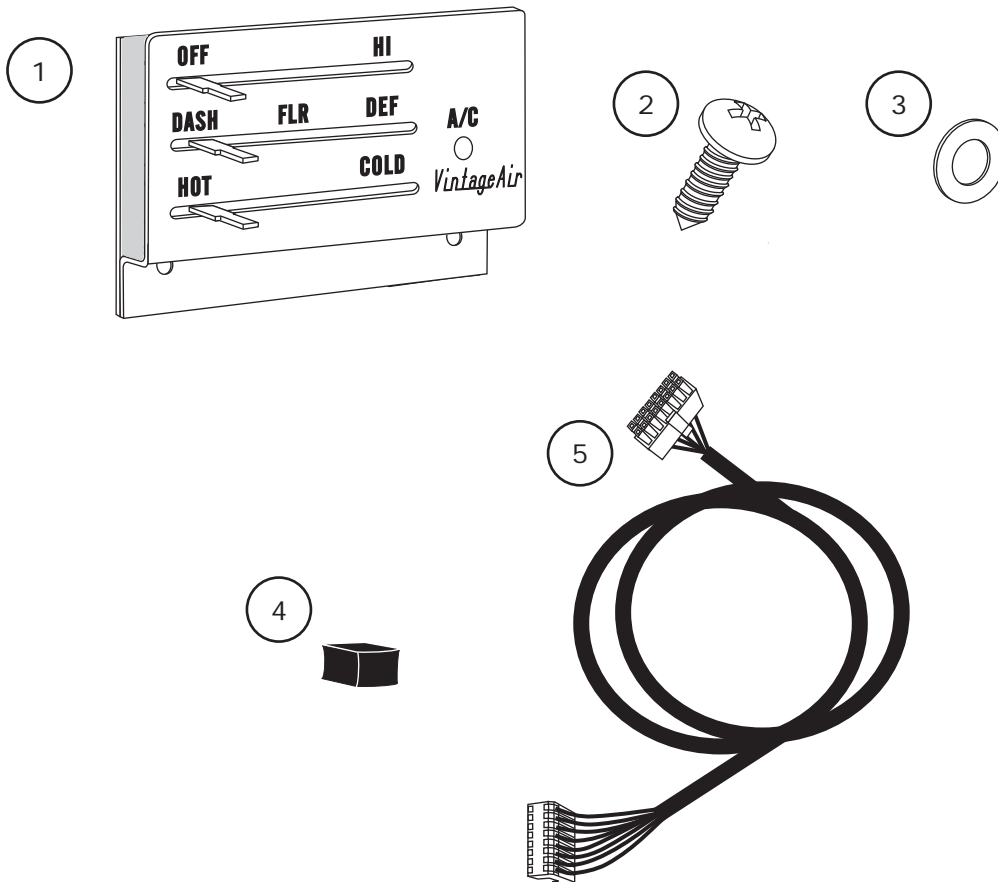

NOTE: Images may not depict actual parts and quantities.
Refer to packing list for actual parts and quantities.