

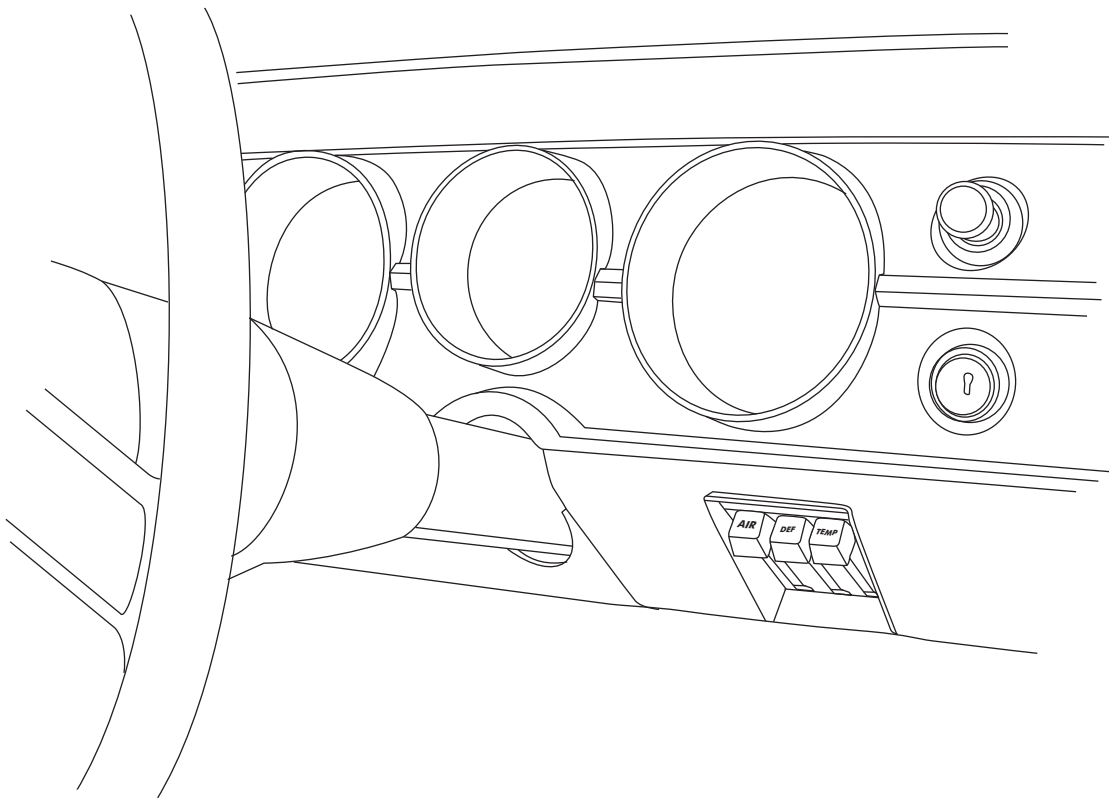

1964-65 Chevrolet Chevelle

without Factory Air
Control Panel Conversion Kit
(473064)



18865 Goll St. San Antonio, TX 78266
Phone: 800-862-6658
Sales: sales@vintageair.com
Tech Support: tech@vintageair.com
www.vintageair.com



www.vintageair.com

Table of Contents

Cover.....	1
Table of Contents.....	2
Packing List/Parts Disclaimer.....	3
OEM Control Panel Removal.....	4
Cable Converter Assembly Modification, Cable Converter Assembly Mounting Clamp Installation.....	5
Temperature Cable Converter Assembly Installation, Temperature Control Harness.....	6
Temperature Control Harness (Cont.), Mode Cable Converter Assembly Installation.....	7
Mode Control Harness.....	8
Blower Speed Cable Converter Assembly Installation, Blower Speed Control Harness.....	9
Blower Speed Control Harness (Cont.), Control Harness Final Step.....	10
Control Panel Reinstallation, Final Steps.....	11
Control Panel Calibration Procedure.....	12
Control Panel Calibration Procedure (Cont.).....	13
Gen IV Wiring Diagram.....	14
Gen 5 Wiring Diagram.....	15
Operation of Controls.....	16
Packing List.....	17



www.vintageair.com

Packing List: Control Panel Kit (473064)

No.	Qty.	Part No.	Description
1.	3	112002-SUA	Cable Converter Assembly
2.	1	232002-VUA	Control Harness, Gen IV/Gen 5 Universal
3.	3	65976-VUE	Push-on Ring, 3/16"
4.	3	491010-VUR	Cable Converter Clamp
5.	5	21301-VUP	Tie Wrap, 4"
6.	1	231520	Ground Wire

**** Before beginning installation, open all packages and check contents of shipment. Please report any shortages directly to Vintage Air within 15 days. After 15 days, Vintage Air will not be responsible for missing or damaged items.**

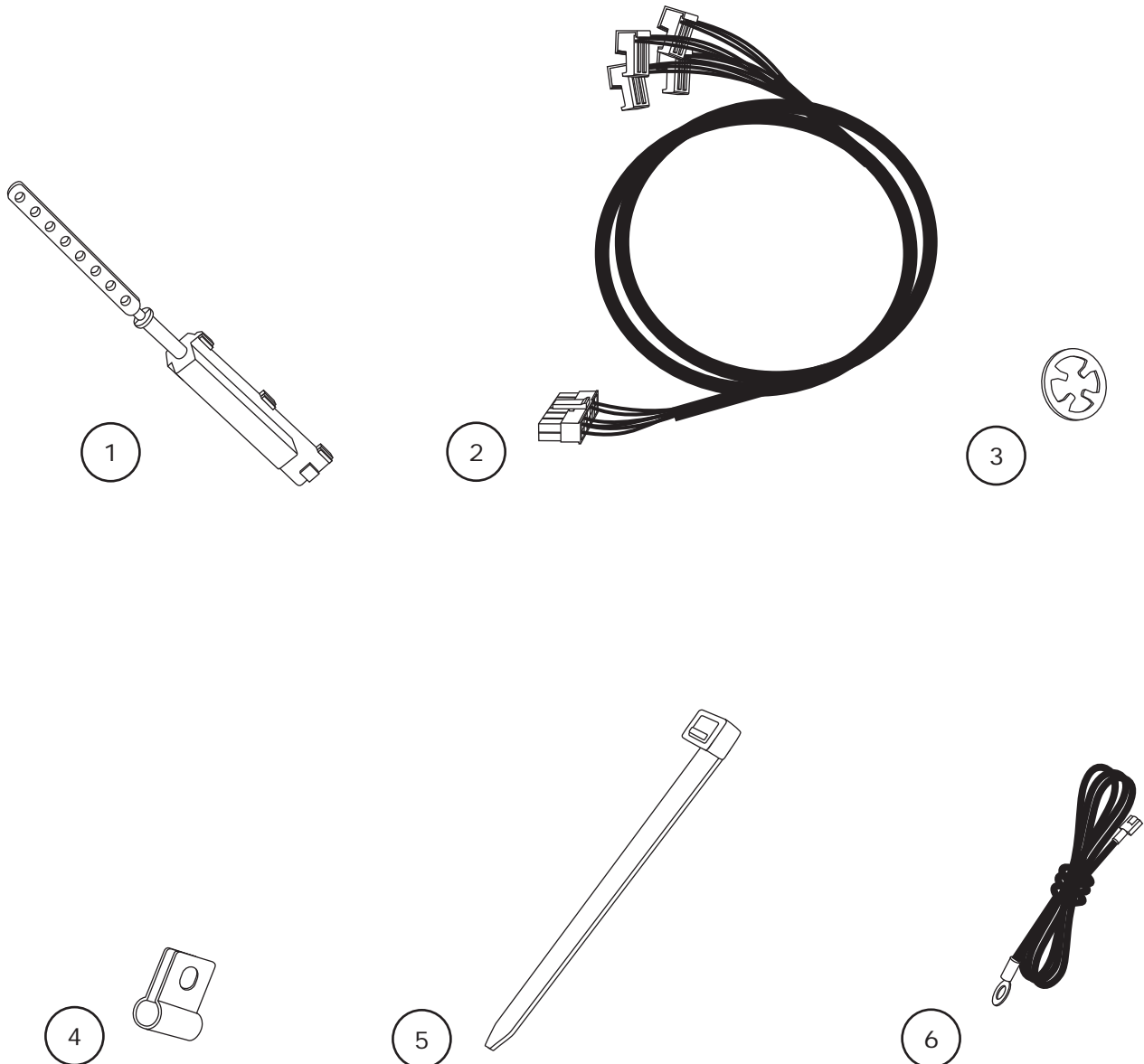

**NOTE: Images may not depict actual parts and quantities.
Refer to packing list for actual parts and quantities.**



www.vintageair.com

OEM Control Panel Removal

Perform the following:

1. Remove (4) OEM screws from the bottom of the dash (retain) (See Figure 1, below).
2. Disconnect all cables and wires from the back side of the OEM controls.
3. Remove the OEM control panel.

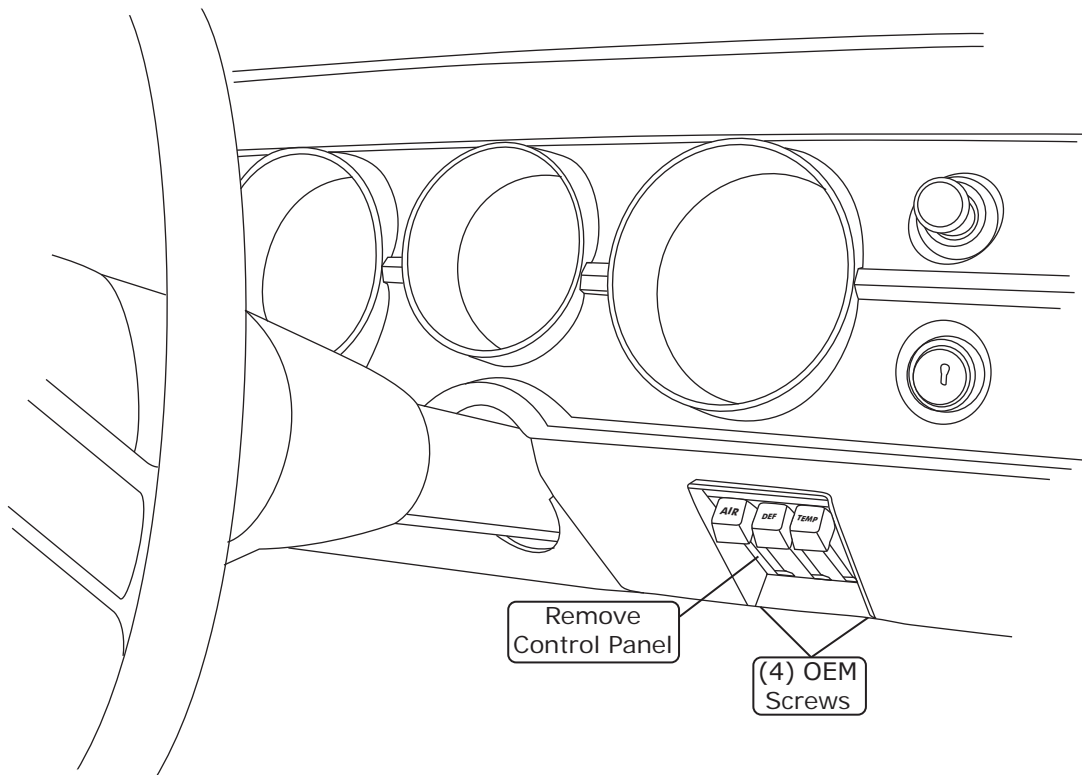

Figure 1



www.vintageair.com

Cable Converter Assembly Modifications

1. Locate the (3) cable converter assemblies. Using a pair of wire cutters, cut the cable converter push rods as shown in Figure 2, below.
2. Trim each cable converter rod, rounding off corners as shown in Figure 2a, below.

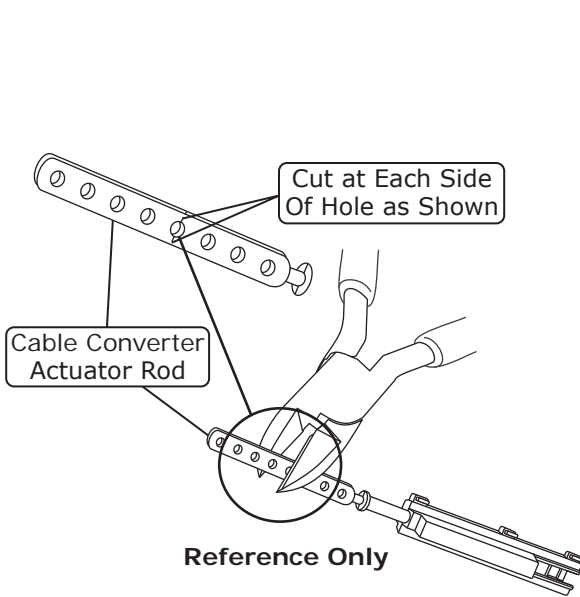
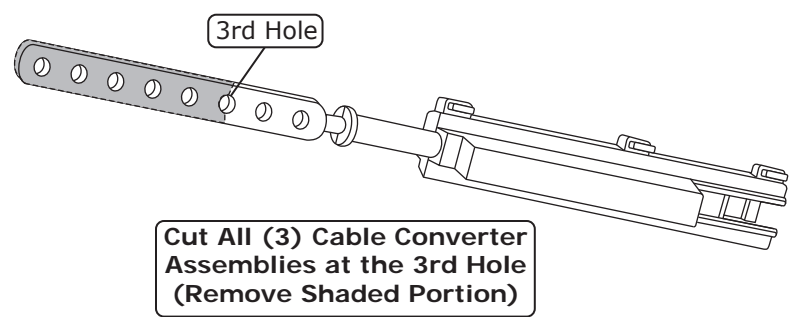

Figure 2

Trim Cable Converter Actuator Rods and Round Off Corners

Figure 2a



Cable Converter Assembly Mounting Clamp Installation

1. Install the cable converter assembly mounting clamps. **NOTE:** Orient clamps in relation to the (3) housing snaps on the cable converter assembly as shown in Figure 3, below.

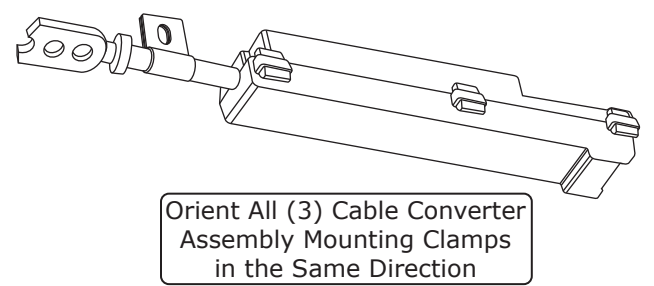
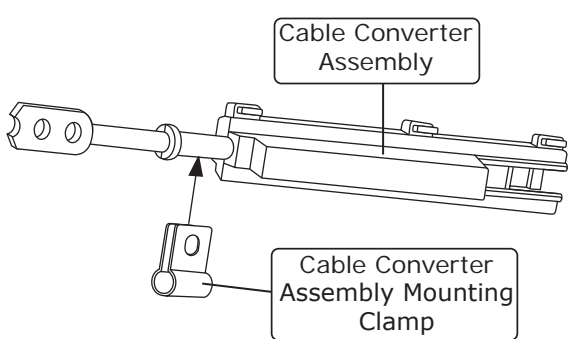

Figure 3



www.vintageair.com

Temperature Cable Converter Assembly Installation

1. Install the cable converter assembly onto the temperature lever by attaching the cable converter push rod to the OEM cable mounting stud on the lever (See Figure 4, below).
2. Secure the cable converter assembly to the control panel using the OEM screw in the OEM cable clamp mounting location as shown in Figure 4, below.
3. Since the cable converter assembly can slide back and forth in the clamp before the screw is tightened, position the cable converter assembly such that the flat part of the rod is as close to flush as possible with the end of the housing at the lever's innermost position (See Figure 4, below).
4. Secure the cable converter lever push rod to the OEM cable mounting stud using a 3/16" push-on ring as shown in Figure 4, below.

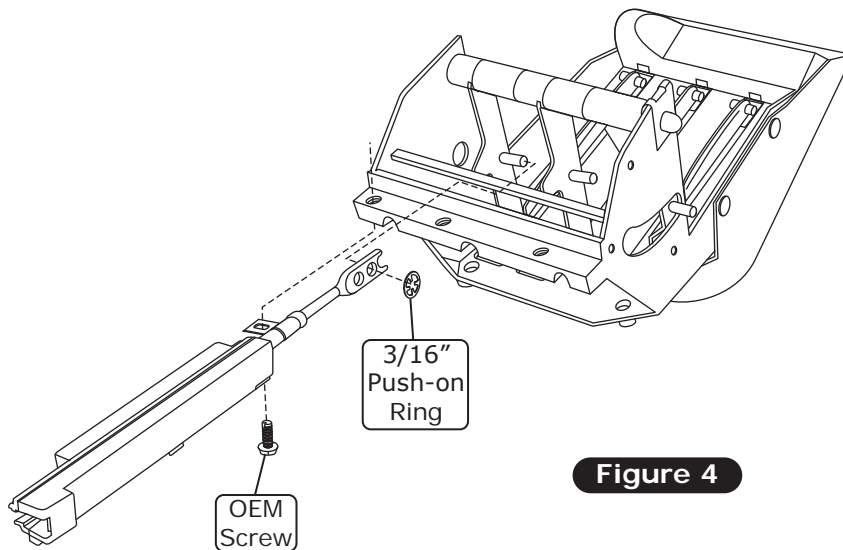
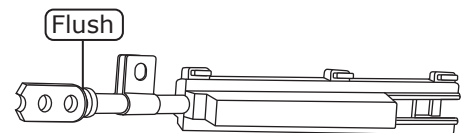
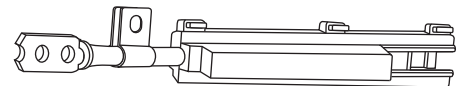

Figure 4



Rod Shown in Approximately Innermost Position



NOTE: Do not allow rod to separate housing when rod is in innermost position.

Temperature Control Harness

1. Locate the control panel wiring harness, and plug the corresponding connector into the correct cable converter assembly as shown in Figure 5, below.

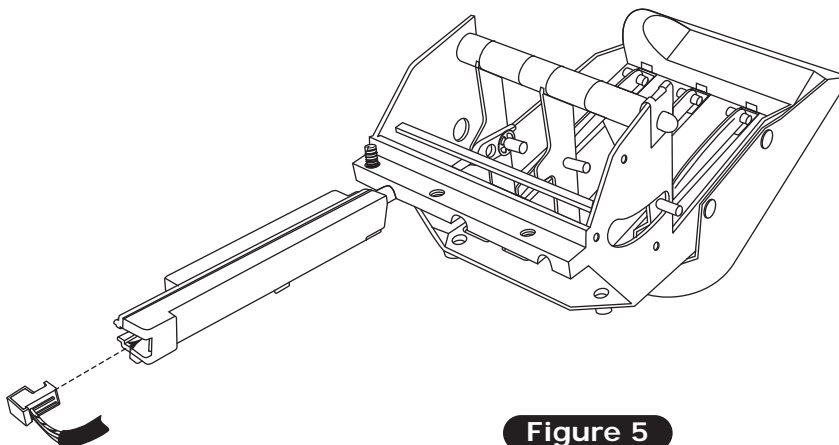
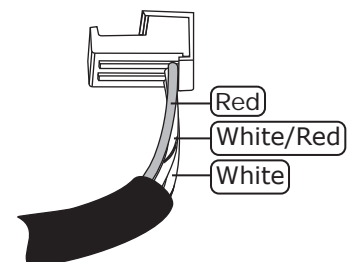

Figure 5



Temperature Cable Converter Assembly



www.vintageair.com

Temperature Control Harness (Cont.)

1. Once the connector is correctly plugged into the cable converter assembly, secure the wires to the cable converter assembly using one of the supplied tie wraps. The tie wrap must be located between the end of the wire jacket and the step in the cable converter housing, forcing a bend in each wire as it passes over the step in the cable converter housing. The head of the tie wrap must fall on the edge of the housing to remain tight. Ensure that the tie wrap is tight enough that the wires cannot move (See Figure 6, below).

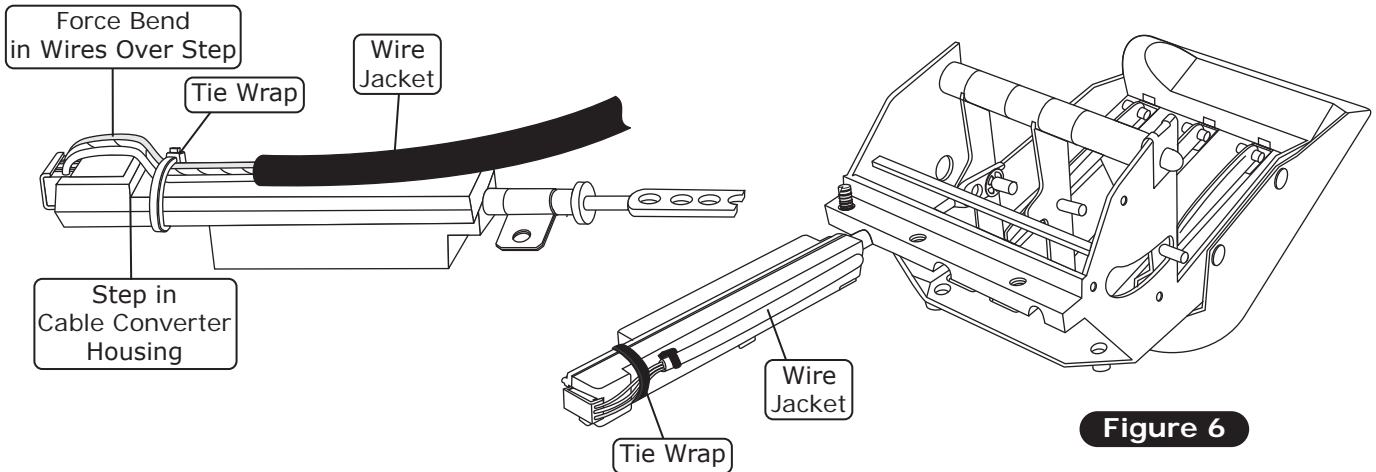

Figure 6

Mode Cable Converter Assembly Installation

1. Install the cable converter assembly onto the mode lever by attaching the cable converter push rod to the OEM cable mounting stud on the lever (See Figure 7, below).
2. Secure the cable converter assembly to the control panel using the OEM screw in the OEM cable clamp mounting location as shown in Figure 7, below.
3. Since the cable converter assembly can slide back and forth in the clamp before the screw is tightened, position the cable converter assembly such that the flat part of the rod is as close to flush as possible with the end of the housing at the lever's innermost position (See Figure 7, below).
4. Secure the cable converter lever push rod to the OEM cable mounting stud using a 3/16" push-on ring as shown in Figure 7, below.

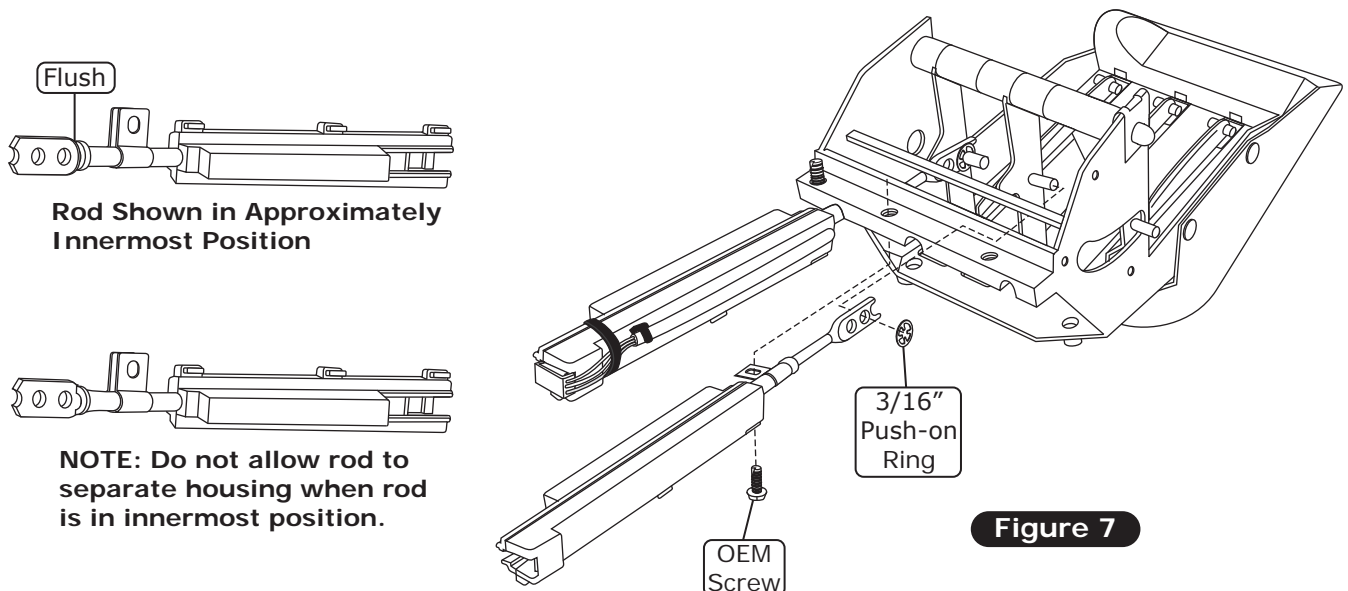

Figure 7



www.vintageair.com

Mode Control Harness

1. Locate the control panel wiring harness, and plug the corresponding connector into the correct cable converter assembly as shown in Figure 8, below.
2. Once the connector is correctly plugged into the cable converter assembly, secure the wires to the cable converter assembly using one of the supplied tie wraps. The tie wrap must be located between the end of the wire jacket and the step in the cable converter housing, forcing a bend in each wire as it passes over the step in the cable converter housing. The head of the tie wrap must fall on the edge of the housing to remain tight. Ensure that the tie wrap is tight enough that the wires cannot move (See Figure 9, below).

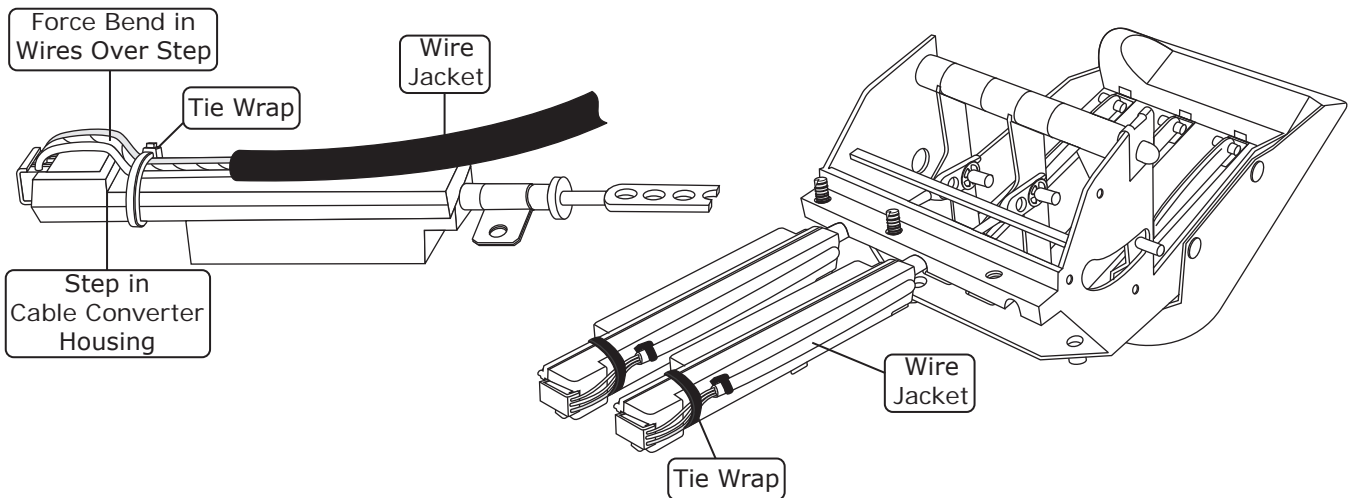
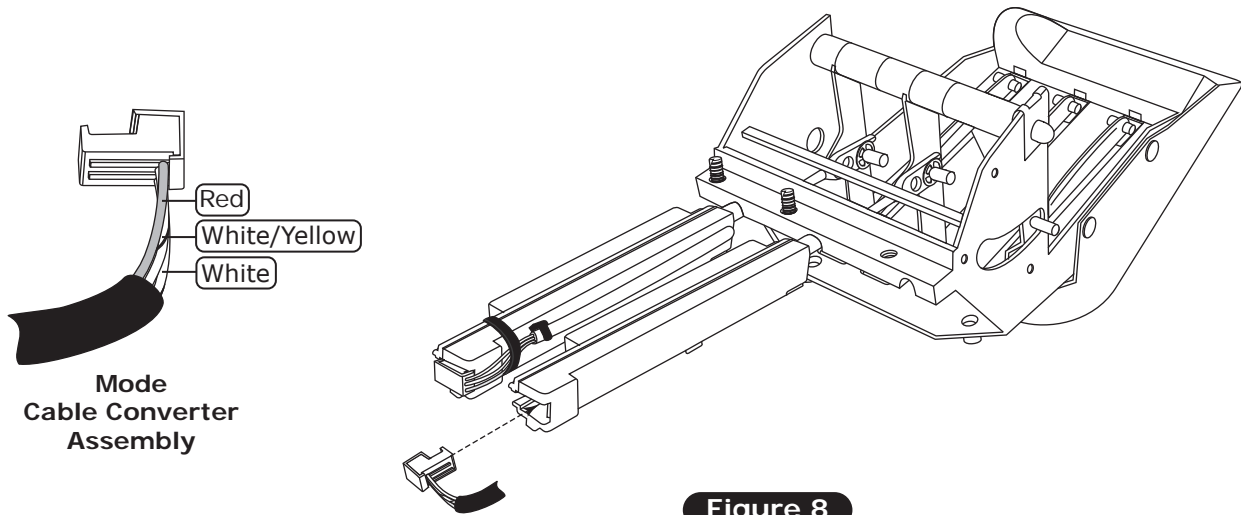



www.vintageair.com

Blower Speed Cable Converter Assembly Installation

1. Install the cable converter assembly onto the blower speed lever by attaching the cable converter push rod to the OEM cable mounting stud on the lever (See Figure 10, below).
2. Secure the cable converter assembly to the control panel using the OEM screw in the OEM cable clamp mounting location as shown in Figure 10, below.
3. Since the cable converter assembly can slide back and forth in the clamp before the screw is tightened, position the cable converter assembly such that the flat part of the rod is as close to flush as possible with the end of the housing at the lever's innermost position (See Figure 10, below).
4. Secure the cable converter lever push rod to the OEM cable mounting stud using a 3/16" push-on ring as shown in Figure 10, below.

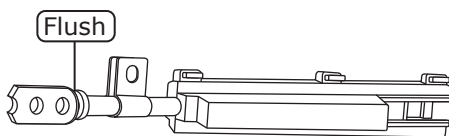

Rod Shown in Approximately Innermost Position

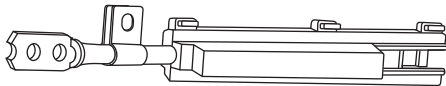

NOTE: Do not allow rod to separate housing when rod is in innermost position.

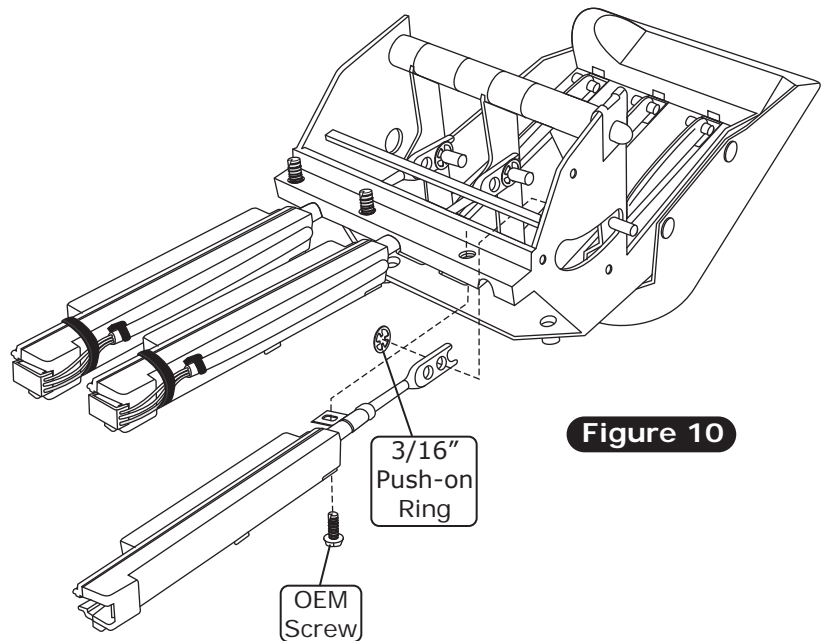
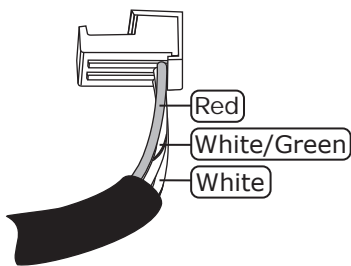

Figure 10

Blower Speed Control Harness

1. Locate the control panel wiring harness, and plug the corresponding connector into the correct cable converter assembly as shown in Figure 11, below.



Blower Speed Cable Converter Assembly

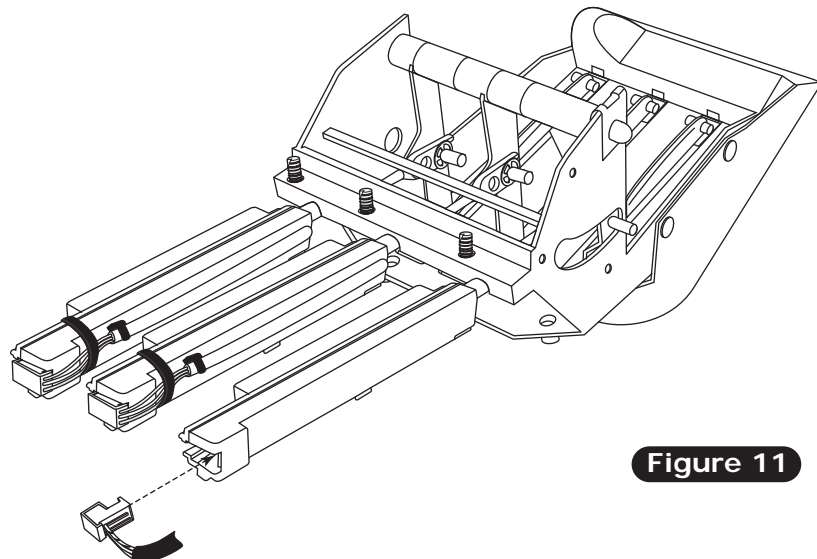

Figure 11



www.vintageair.com

Blower Speed Control Harness (Cont.)

1. Once the connector is correctly plugged into the cable converter assembly, secure the wires to the cable converter assembly using one of the supplied tie wraps. The tie wrap must be located between the end of the wire jacket and the step in the cable converter housing, forcing a bend in each wire as it passes over the step in the cable converter housing. The head of the tie wrap must fall on the edge of the housing to remain tight. Ensure that the tie wrap is tight enough that the wires cannot move (See Figure 12, below).

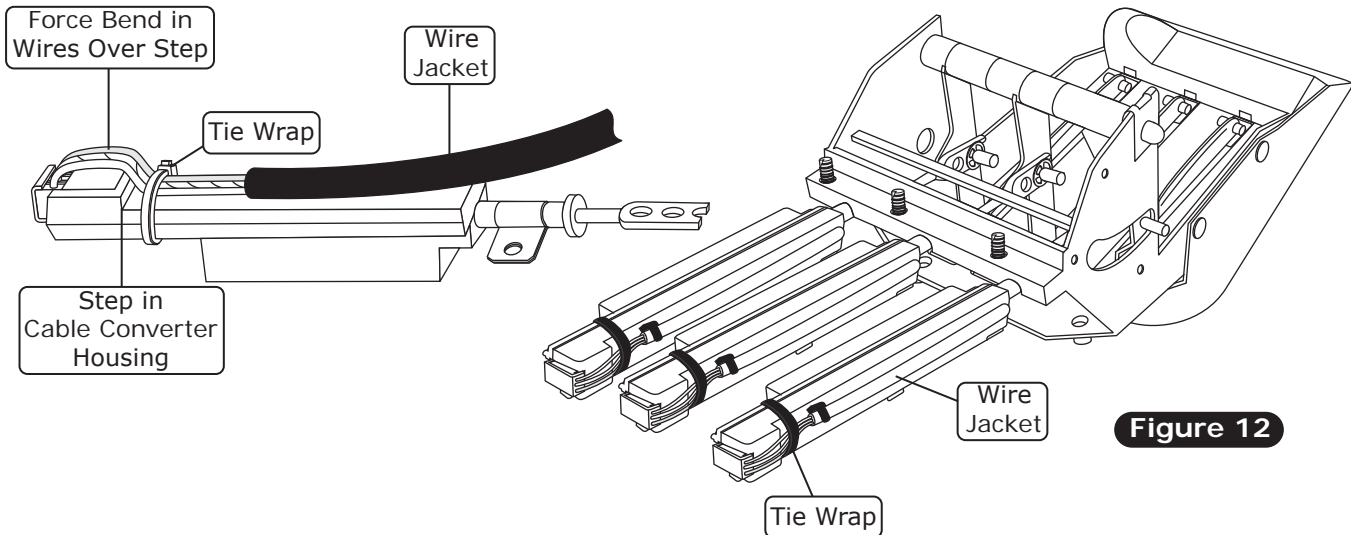

Figure 12

Control Harness Final Step

1. Using the supplied tie wraps, tie the wires to the control panel as shown in Figure 13, below. Confirm the wires are secured and do not interfere with lever operation or the cable converter assemblies.

NOTE: Tie the unused wire to the control panel approximately as shown. Ensure that the wire does not interfere with levers or cable converter assemblies.

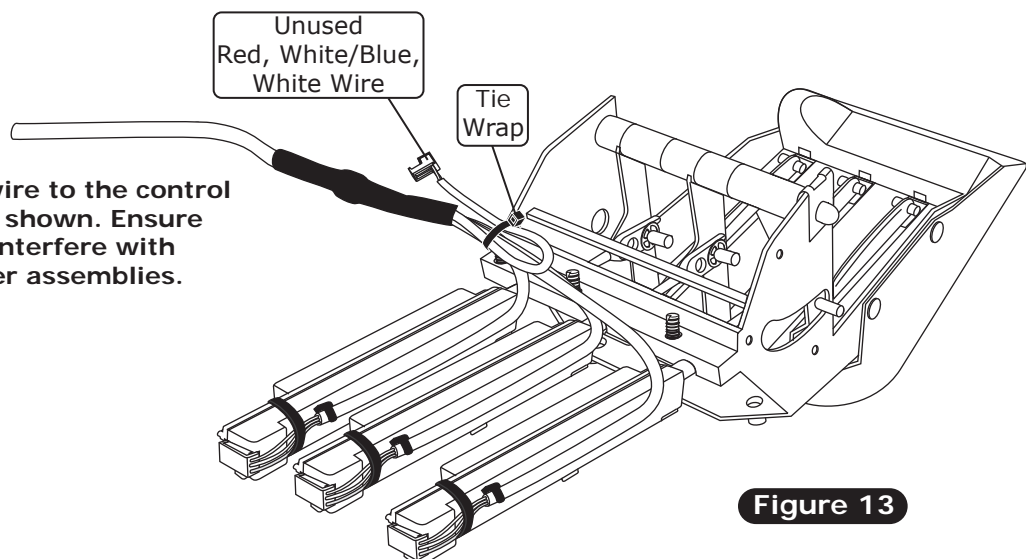

Figure 13



www.vintageair.com

Control Panel Reinstallation

1. Reinstall the control panel into the dash using the (4) OEM screws.

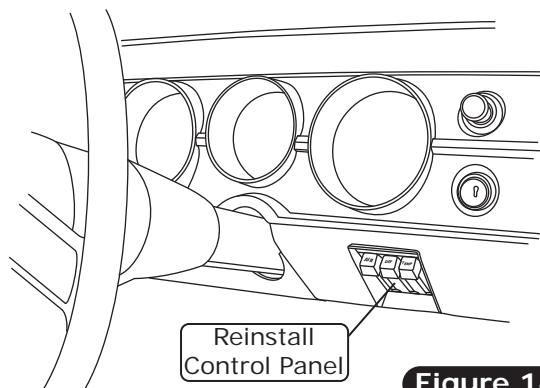

Figure 14

Final Steps

1. Plug the wiring harnesses into the ECU module on the sub case (See Figure 15, below).
2. Wire according to the wiring diagram on Page 14 or 15.
3. Calibration procedure and operation instructions:
 - A. Calibrating the control panel will set the range of travel for the cable converters connected to the OEM control panel levers. Performing this procedure will set the limits of the cable converters at their highest and lowest points.
 - B. Locate the gray wire with an unused connector in the wiring harness near the cable harness relay. This wire is labeled PROGRAM on the wiring diagram.
 - C. It will be necessary to ground the gray wire for approximately five seconds while moving the controls, so it is sometimes helpful to attach one end of the white jumper to the vehicle's ground (for example, the chassis) and have the other end ready to connect to the gray PROGRAM wire when the procedure requires it.
 - D. To calibrate the control panel, follow the calibration procedures on Pages 12 & 13.

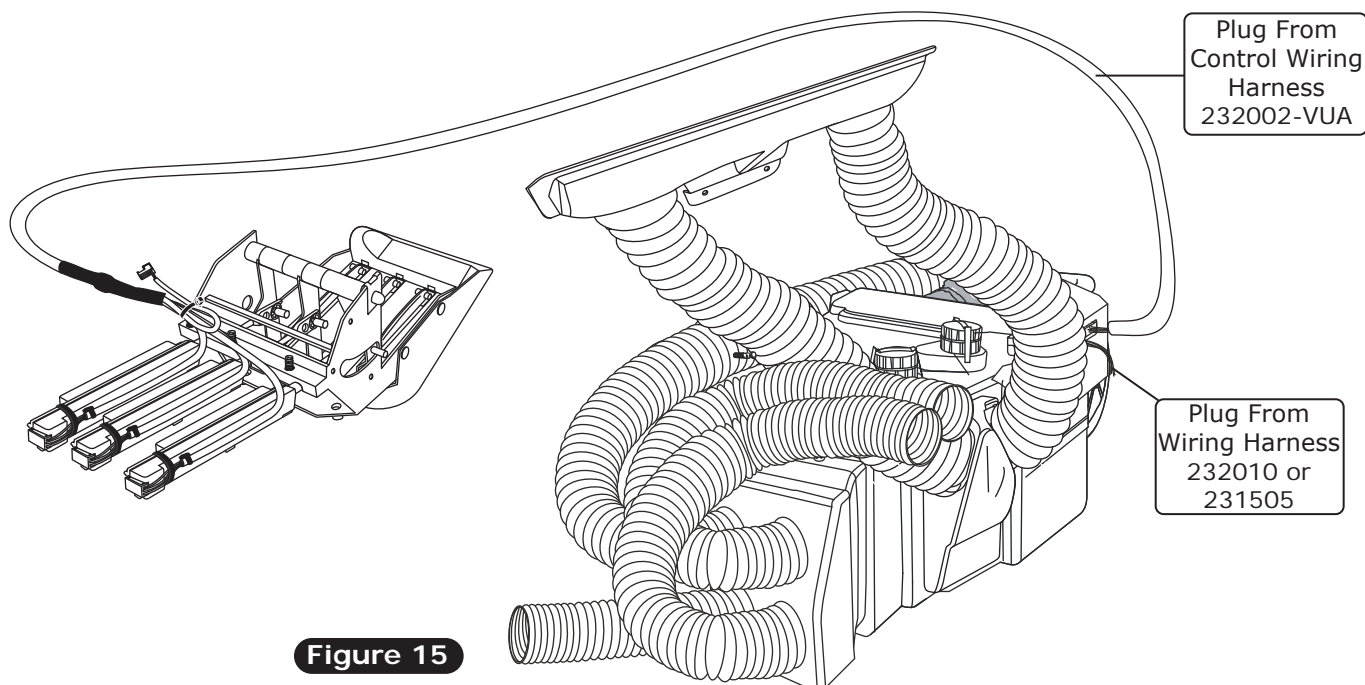

Figure 15



www.vintageair.com

Control Panel Calibration Procedure

On Vintage Air Gen IV and Gen 5 systems using cable converters or replacement electronic controls, it is necessary to calibrate the system to your specific control panel. This procedure ensures that the travel of your control panel levers or knobs is translated into precise control of the blower speed, temperature blend and mode door position. Please carefully read and understand these procedures before beginning. The procedure may be repeated as many times as necessary to get it right.

Gen IV Systems:

In preparation for calibration, you will need to attach the supplied white ground jumper wire (PN 231520) to a suitable chassis ground. This jumper wire must be easily connected to the gray programming wire located in the main Gen IV wiring harness next to the compressor relay. During the calibration procedure, you will connect the white jumper to the gray program wire, which will "teach" the Gen IV ECU the upper limits of the control levers or knobs. The blower will momentarily change speeds, signaling that the upper limits have been "learned". You will move the levers or knobs to opposite extreme positions of their travel and then disconnect the white jumper. The blower will pulse on/off, signaling that the lower limits have been learned and that the calibration procedure is complete.

Gen 5 Systems:

In preparation for calibration, you will need to attach the supplied white ground jumper wire (PN 231520) to a suitable chassis ground. This jumper wire must be easily connected to the gray programming wire located in the main Gen 5 wiring harness, see the Gen 5 wiring diagram and instructions for more information. During the calibration procedure, you will connect the white jumper to the gray program wire, and ground, which will then put the ECU into calibration mode. When the ECU is in calibration mode, the blower will default to medium speed and the ECU will flash a solid red light. Once in calibration mode you will cycle the controls as indicated in the calibration procedure on the next page. When complete, the jumper and program wire will be disconnected. The blower will turn off indicating calibration is complete.



www.vintageair.com

Control Panel Calibration Procedure (Cont.)

1. Turn on the ignition switch (Do not start the engine).

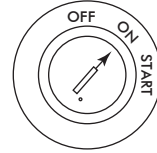

2. Move the control levers/knobs to the positions shown.

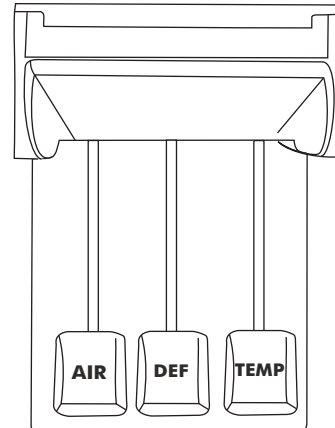

3. Connect the white jumper wire to the gray program wire. Wait approximately 5 seconds for the blower speed to change if using a Gen IV system, if using a Gen 5 system wait for the blower to default to medium speed.

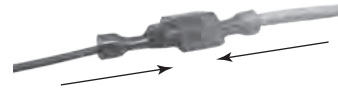

4. Move the control levers/knobs to the positions shown.

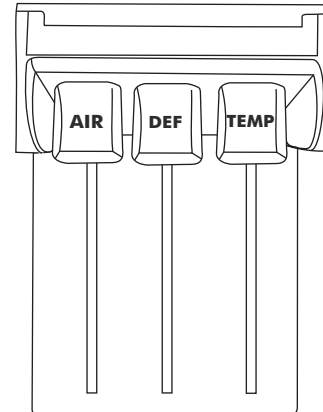

5. Disconnect the white jumper wire from the gray program wire. The blower speed will change if using a Gen IV system, and will shut off if using a Gen 5 system, indicating completion of the calibration procedure.

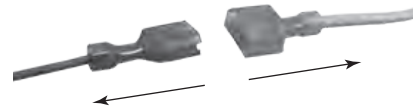

6. Confirm proper operation of controls. Repeat procedure if necessary. When finished, tape over program wire connector with electrical tape to prevent accidental contact with chassis ground.



www.vintageair.com

Gen IV Wiring Diagram

232007-VUR

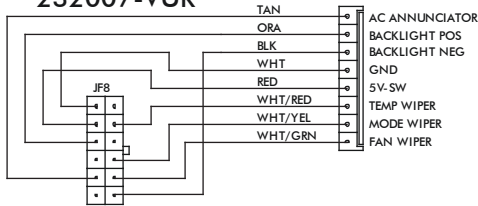

VIEWED FROM WIRE SIDE

232002-VUA

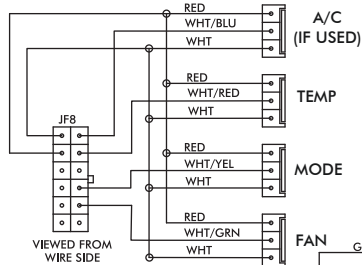

VIEWED FROM WIRE SIDE

PROGRAM

N/A

* DASH LAMP (IF USED)

*** WIDE OPEN THROTTLE SWITCH (OPTIONAL)

WHT

IGNITION SWITCH

RUN

BAT

+ 12v

WHT

COM

WHT

WHT

WHT

WHT

WHT

WHT

WHT

WHT

WHT

WHT

WHT

WHT

WHT

WHT

WHT

WHT

WHT

WHT

WHT

WHT

WHT

WHT

WHT

WHT

WHT

WHT

WHT

WHT

WHT

WHT

WHT

WHT

WHT

WHT

WHT

WHT

WHT

WHT

WHT

WHT

WHT

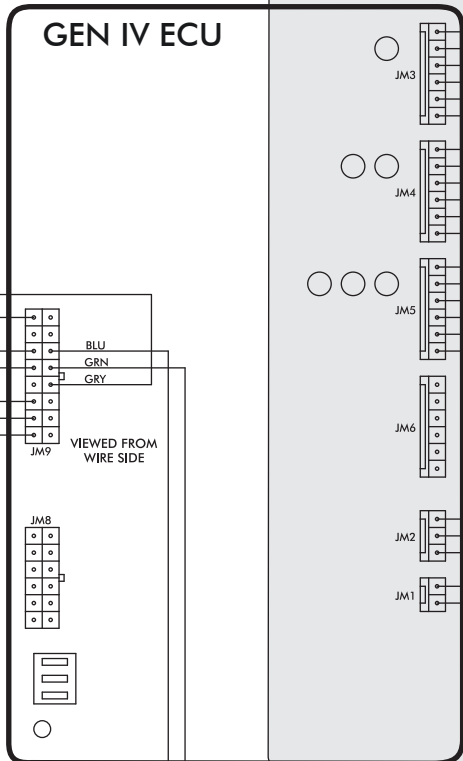

PRE-WIRED

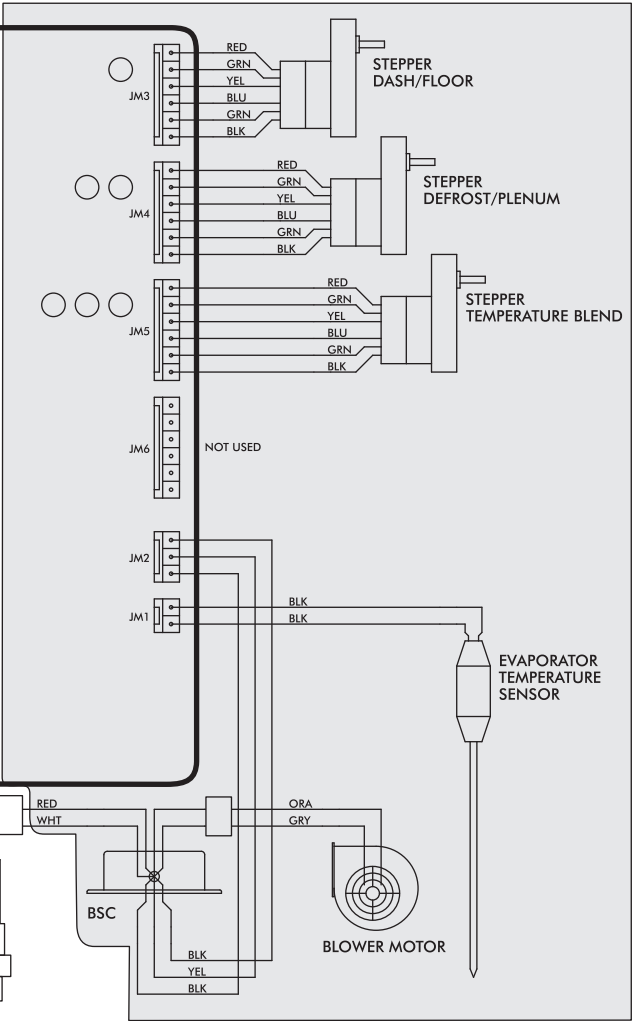

NOTE: = CHASSIS GROUND

* Dash lamp is used only with type 232007-VUR harness.

** Warning: Always mount circuit breaker as close to the battery as possible. (NOTE: Wire between battery and circuit breaker is unprotected and should be carefully routed to avoid a short circuit).

*** Wide open throttle switch contacts close only at full throttle, which disables A/C compressor.



www.vintageair.com

Gen 5 Wiring Diagram

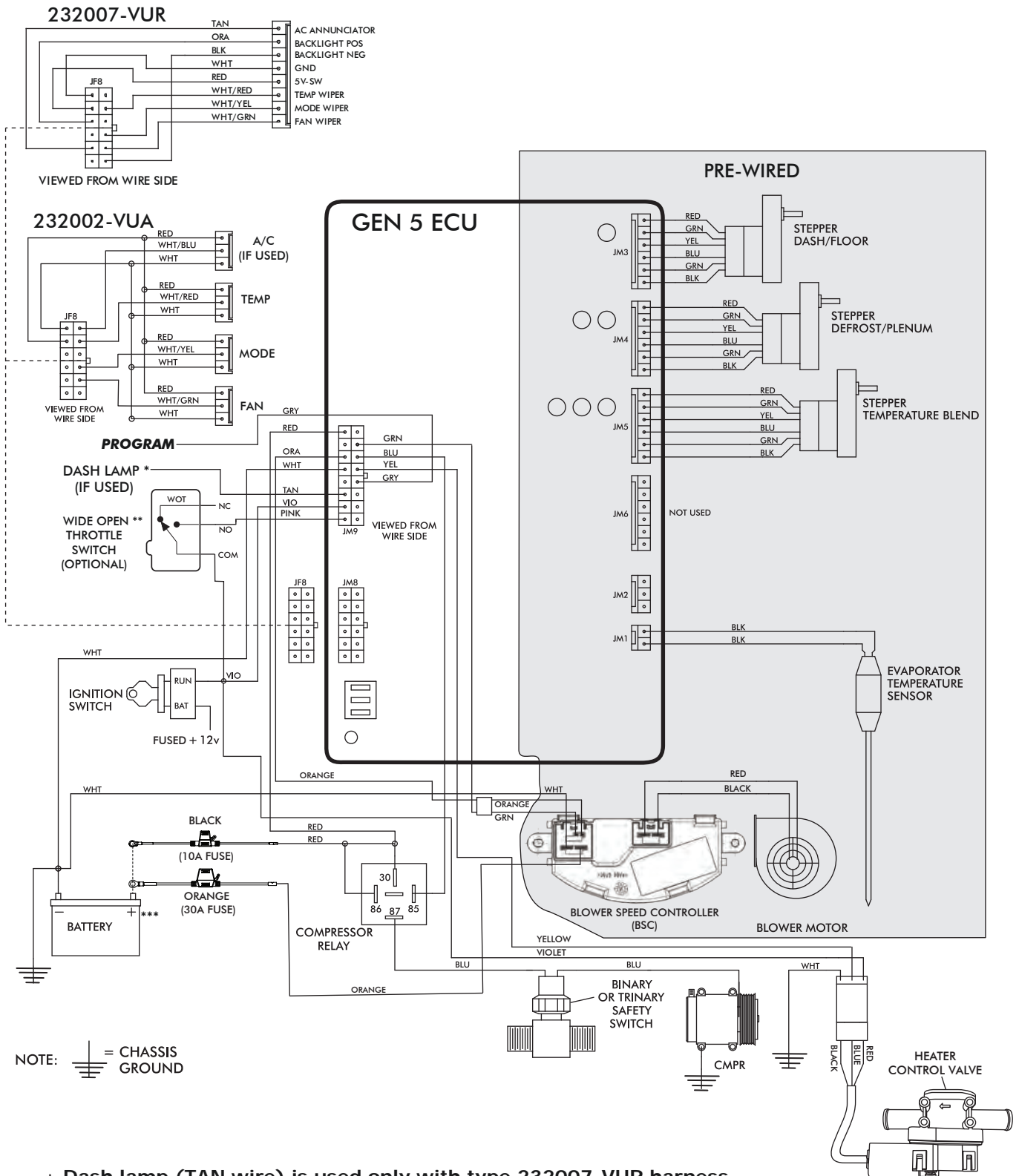

NOTE: = CHASSIS GROUND

- * Dash lamp (TAN wire) is used only with type 232007-VUR harness.
- ** Wide open throttle switch contacts close only at full throttle, which disables A/C compressor.
- *** Install fuse assemblies at or as near to the battery as possible.



www.vintageair.com

Operation of Controls

On Gen IV or Gen 5 systems with three lever/knob controls, the temperature control toggles between heat and A/C operations. To activate A/C, move the temperature lever/knob all the way to cold and then back it off to the desired vent temperature. For heat operation, move the temperature lever/knob all the way to hot and then adjust to the desired vent temperature. The blower will momentarily change speed, each time you toggle in and out of heat and A/C operations, to indicate the change. **NOTE: For proper control panel function, refer to Pages 12 & 13 for calibration procedure.**

Blower Speed

This lever/knob controls blower speed, from OFF to HI.

Mode Control

This lever/knob controls the mode positions, from DASH to FLOOR to DEFROST, with a blend in between.

Temperature Control

This lever/knob controls the temperature, from HOT to COLD.

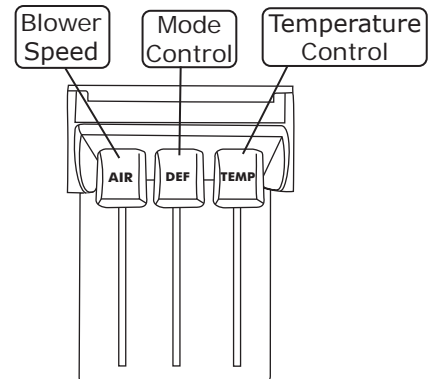

A/C Operation

Blower Speed

Adjust to desired speed.

Mode Control

Adjust to desired mode position (DASH position recommended).

Temperature Control

For A/C operation, adjust to coldest position to engage compressor (Adjust between HOT and COLD to reach desired temperature).

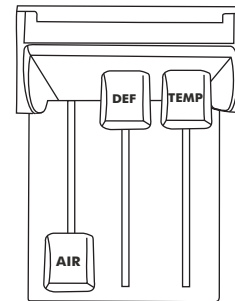

Heat Operation

Blower Speed

Adjust to desired speed.

Mode Control

Adjust to desired mode position (FLOOR position recommended).

Temperature Control

For maximum heating, adjust to hottest position (Adjust between HOT and COLD to reach desired temperature).

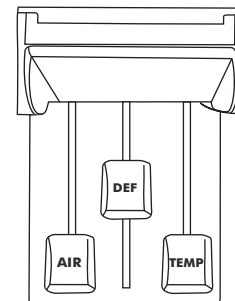

Defrost/De-fog Operation

Blower Speed

Adjust to desired speed.

Temperature Control

Adjust to desired temperature.

Mode Control

Adjust to DEFROST position for maximum defrost, or between FLOOR and DEFROST positions for a bi-level blend (Compressor is automatically engaged).

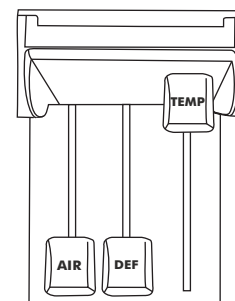



www.vintageair.com

Packing List: Control Panel Kit (473064)

No.	Qty.	Part No.	Description
1.	3	112002-SUA	Cable Converter Assembly
2.	1	232002-VUA	Control Harness, Gen IV/Gen 5 Universal
3.	3	65976-VUE	Push-on Ring, 3/16"
4.	3	491010-VUR	Cable Converter Clamp
5.	5	21301-VUP	Tie Wrap, 4"
6.	1	231520	Ground Wire

Checked By: _____
Packed By: _____
Date: _____

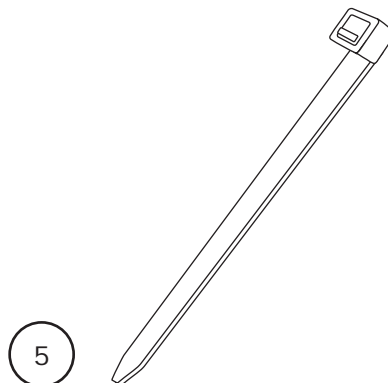
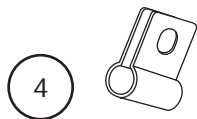
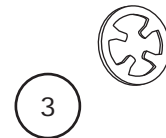
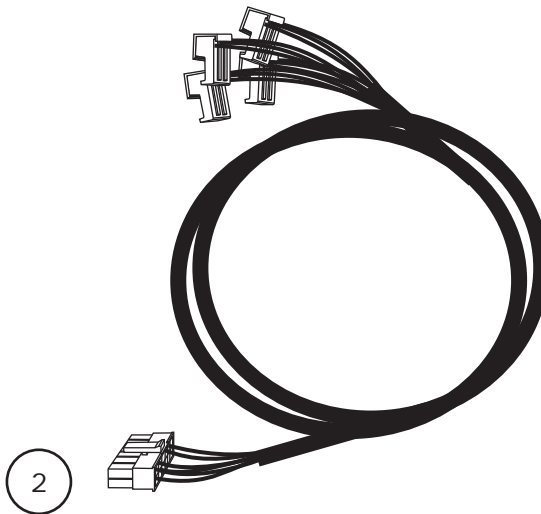
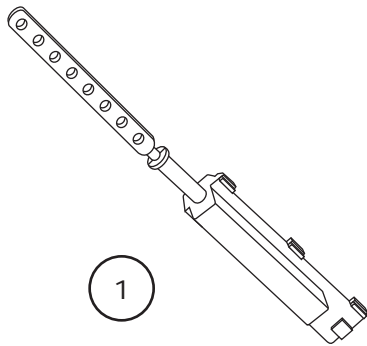

**NOTE: Images may not depict actual parts and quantities.
Refer to packing list for actual parts and quantities.**