



# 1971-73 Ford Mustang

Control Panel Kit  
(474163)



18865 Goll St. San Antonio, TX 78266  
Phone: 800-862-6658  
Sales: [sales@vintageair.com](mailto:sales@vintageair.com)  
Tech Support: [tech@vintageair.com](mailto:tech@vintageair.com)  
[www.vintageair.com](http://www.vintageair.com)



[www.vintageair.com](http://www.vintageair.com)

# Table of Contents

Cover.....	1
Table of Contents.....	2
Packing List/Parts Disclaimer.....	3
OEM Control Panel Removal.....	4
Control Panel Installation.....	5
Control Panel Calibration Procedure.....	6
Control Panel Calibration Procedure (Cont.).....	7
Gen IV Wiring Diagram.....	8
Gen 5 Wiring Diagram.....	9
Operation of Controls.....	10
Packing List.....	11

## Important Notice—Please Read

- This control panel kit is designed for the 1971-73 Mustang with or without factory air conditioning.
- The ECU module is located on the evaporator. When using a Vintage Air supplied control panel, connect the tan wire from the GEN IV evaporator wiring harness (232010) or the Gen 5 evaporator wiring harness (231505) to the factory dash lights to enable backlighting.



www.vintageair.com

# Packing List: Control Panel Kit (474163)

No.	Qty.	Part No.	Description
1.	1	474162	Control Panel Assembly
2.	4	182353	Screw, #8 x 1/2", Wide Head
3.	1	231520	Ground Wire, 12" White, 16 GA with 1/4" Male Spade
4.	1	232007-VUR	Control Harness, Gen IV/5 Universal

**\*\* Before beginning installation, open all packages and check contents of shipment. Please report any shortages directly to Vintage Air within 15 days. After 15 days, Vintage Air will not be responsible for missing or damaged items.**

1



2



3



4



**NOTE: Images may not depict actual parts and quantities. Refer to packing list for actual parts and quantities.**



www.vintageair.com

## OEM Control Panel Removal

### Perform the following:

1. Disconnect the battery.
2. Remove the (4) screws that secure the trim bezel to the dash (See Photo 1, below). Remove the trim and retain the screws.
3. Remove the (4) screws that secure the OEM control panel to the dash (discard) (See Photo 2, below).
4. Pull the control panel out of the dash, and disconnect all cables, vacuum lines and electrical connections from the back as shown in Photo 3, below.
5. Remove the OEM control panel.

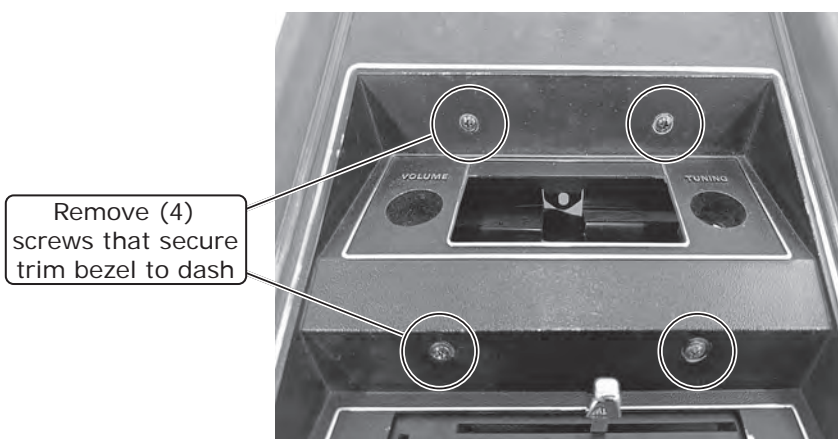

Photo 1

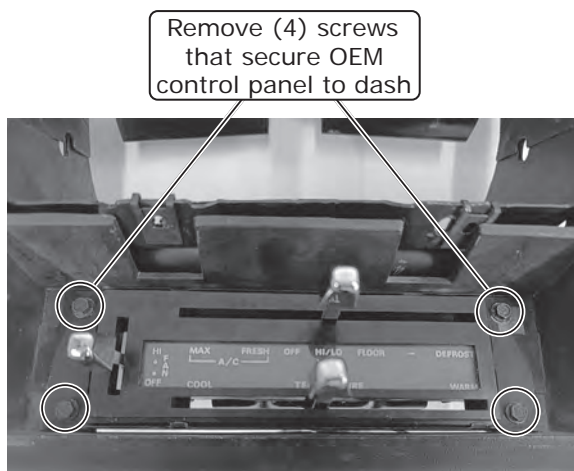

Photo 2

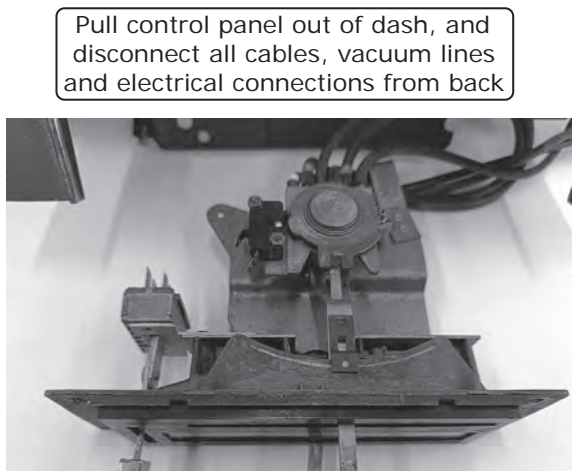

Photo 3



www.vintageair.com

## Control Panel Installation

1. Connect the control harness to the rear of the control panel assembly, then feed the harness through the opening and towards the ECU located on the evaporator module (See Photo 1, below).
2. Install the control panel assembly into the opening on the dash, and secure it with (4) #8 x 1/2" wide head screws (See Photo 2, below).
3. Reinstall the trim bezel, then secure it with the (4) OEM screws (See Photo 3, below).
4. Check the alignment with the bezel, and use the adjustment slots in the control panel bracket to make minor adjustments if necessary.
5. Plug the control harness into the ECU on the evaporator module (See Figure 1, below).
6. Follow the calibration procedures on Pages 6 and 7.

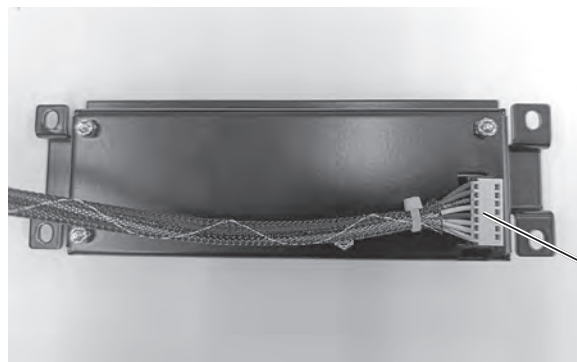

Connect control harness to rear of control panel, then feed harness through opening and towards ECU located on evaporator module

Photo 1

Install control panel into opening on dash, and secure it with (4) #8 x 1/2" wide head screws

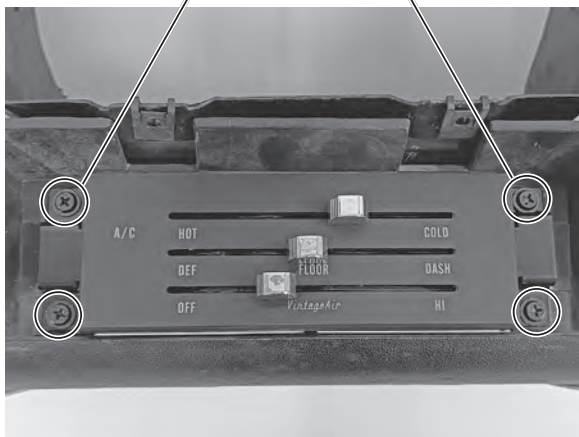

Photo 2

Reinstall trim bezel, then secure it with the (4) OEM screws



Photo 3

Plug control harness into ECU on evaporator module

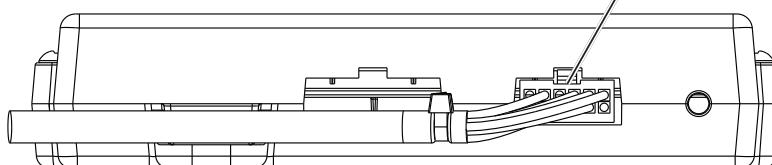

Figure 1



[www.vintageair.com](http://www.vintageair.com)

## ***Control Panel Calibration Procedure***

On Vintage Air Gen IV and Gen 5 systems using cable converters or replacement electronic controls, it is necessary to calibrate the system to your specific control panel. This procedure ensures that the travel of your control panel levers or knobs is translated into precise control of the blower speed, temperature blend and mode door position. Please carefully read and understand these procedures before beginning. The procedure may be repeated as many times as necessary to get it right.

### **Gen IV Systems:**

In preparation for calibration, you will need to attach the supplied white ground jumper wire (PN 231520) to a suitable chassis ground. This jumper wire must be easily connected to the gray programming wire located in the main Gen IV wiring harness next to the compressor relay. During the calibration procedure, you will connect the white jumper to the gray program wire, which will "teach" the Gen IV ECU the upper limits of the control levers or knobs. The blower will momentarily change speeds, signaling that the upper limits have been "learned". You will move the levers or knobs to opposite extreme positions of their travel and then disconnect the white jumper. The blower will pulse on/off, signaling that the lower limits have been learned and that the calibration procedure is complete.

### **Gen 5 Systems:**

In preparation for calibration, you will need to attach the supplied white ground jumper wire (PN 231520) to a suitable chassis ground. This jumper wire must be easily connected to the gray programming wire located in the main Gen 5 wiring harness, see the Gen 5 wiring diagram and instructions for more information. During the calibration procedure, you will connect the white jumper to the gray program wire, and ground, which will then put the ECU into calibration mode. When the ECU is in calibration mode, the blower will default to medium speed and the ECU will flash a solid red light. Once in calibration mode you will cycle the controls as indicated in the calibration procedure on the next page. When complete, the jumper and program wire will be disconnected. The blower will turn off indicating calibration is complete.



www.vintageair.com

# Control Panel Calibration Procedure (Cont.)

1. Turn on the ignition switch (Do not start the engine).

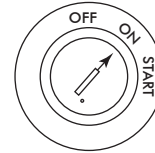

2. Move the control levers/knobs to the positions shown.



3. Connect the white jumper wire to the gray program wire. Wait approximately 5 seconds for the blower speed to change if using a Gen IV system, if using a Gen 5 system wait for the blower to default to medium speed.

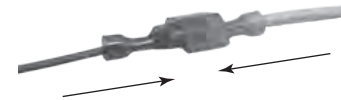

4. Move the control levers/knobs to the positions shown.



5. Disconnect the white jumper wire from the gray program wire. The blower speed will change if using a Gen IV system, and will shut off if using a Gen 5 system, indicating completion of the calibration procedure.

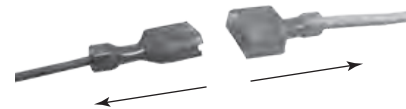

6. Confirm proper operation of controls. Repeat procedure if necessary. When finished, tape over program wire connector with electrical tape to prevent accidental contact with chassis ground.



www.vintageair.com

# Gen IV Wiring Diagram

232007-VUR

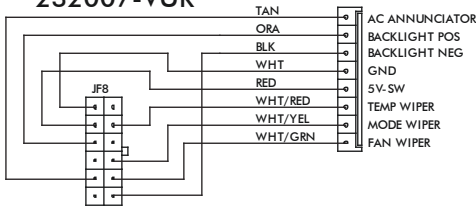

VIEWED FROM WIRE SIDE

232002-VUA

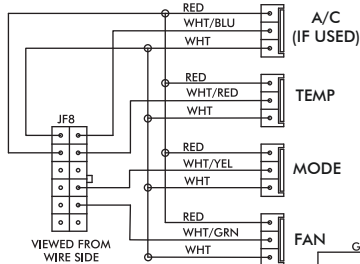

VIEWED FROM WIRE SIDE

PROGRAM

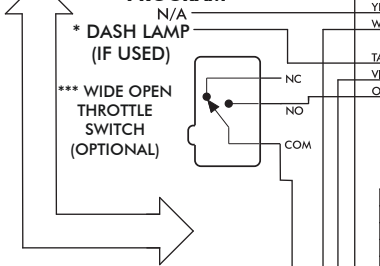

GEN IV ECU

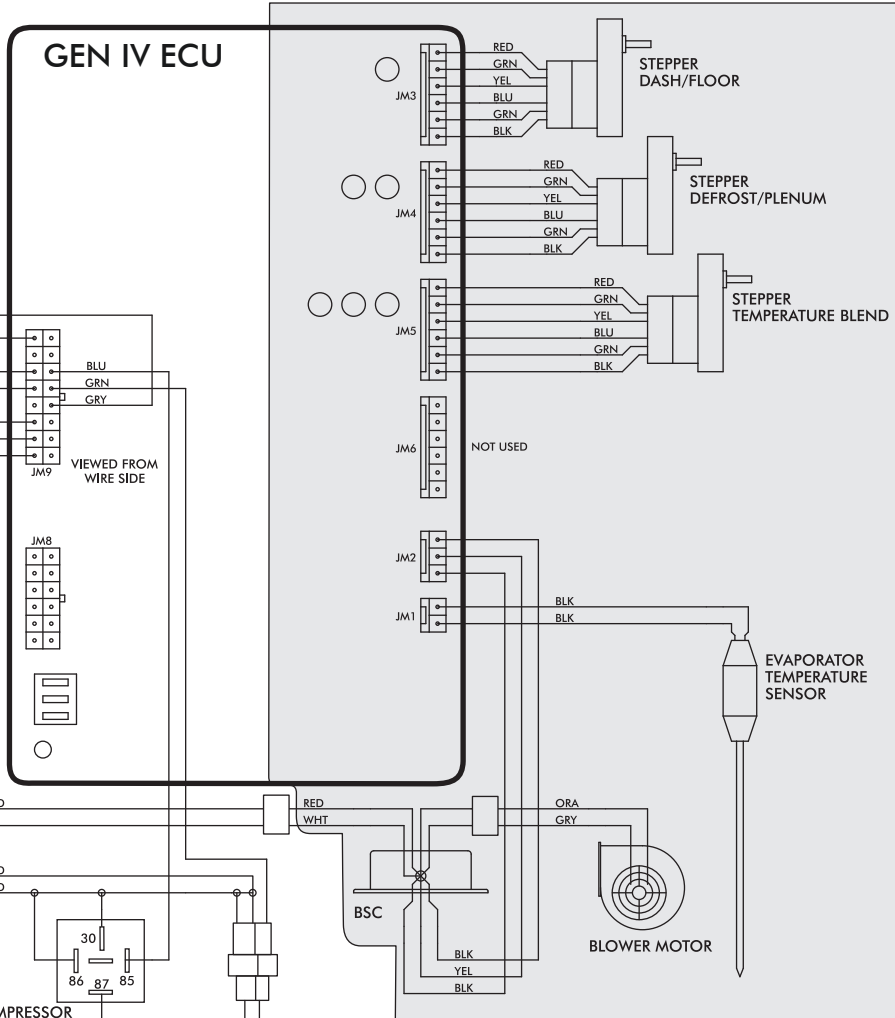

PRE-WIRED

NOTE: = CHASSIS GROUND

\* Dash lamp is used only with type 232007-VUR harness.

\*\* Warning: Always mount circuit breaker as close to the battery as possible. (NOTE: Wire between battery and circuit breaker is unprotected and should be carefully routed to avoid a short circuit).

\*\*\* Wide open throttle switch contacts close only at full throttle, which disables A/C compressor.



www.vintageair.com

# Gen 5 Wiring Diagram

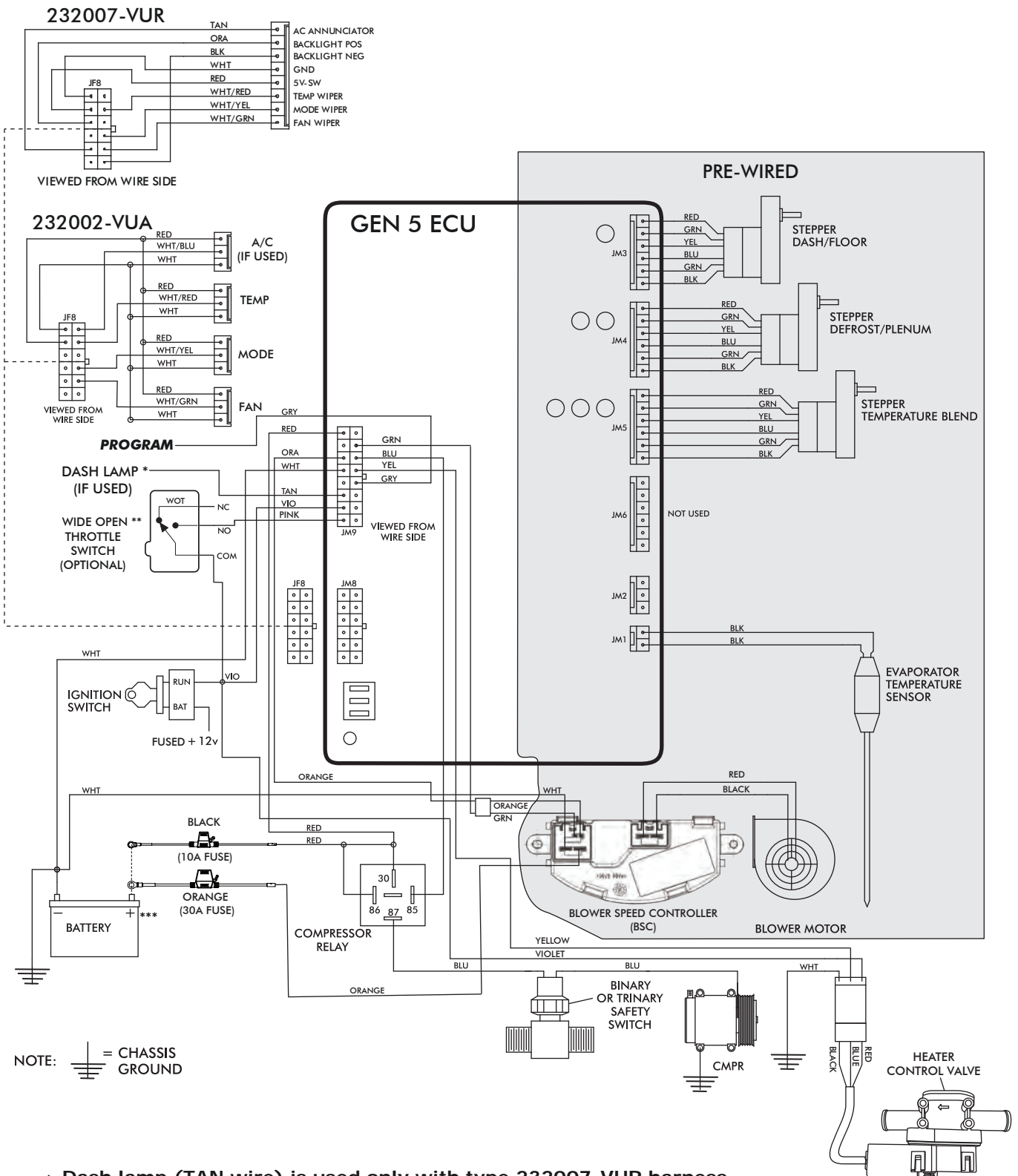

NOTE: = CHASSIS GROUND

- \* Dash lamp (TAN wire) is used only with type 232007-VUR harness.
- \*\* Wide open throttle switch contacts close only at full throttle, which disables A/C compressor.
- \*\*\* Install fuse assemblies at or as near to the battery as possible.



www.vintageair.com

## Operation of Controls

On Gen IV or Gen 5 systems with three lever/knob controls, the temperature control toggles between heat and A/C operations. To activate A/C, move the temperature lever/knob all the way to cold and then back it off to the desired vent temperature. For heat operation, move the temperature lever/knob all the way to hot and then adjust to the desired vent temperature. The blower will momentarily change speed, each time you toggle in and out of heat and A/C operations, to indicate the change. **NOTE: For proper control panel function, refer to Pages 6 and 7 for calibration procedure.**

### Blower Speed

This lever/knob controls blower speed, from OFF to HI.

### Mode Control

This lever/knob controls the mode positions, from DASH to FLOOR to DEFROST, with a blend in between.

### Temperature Control

This lever/knob controls the temperature, from HOT to COLD.

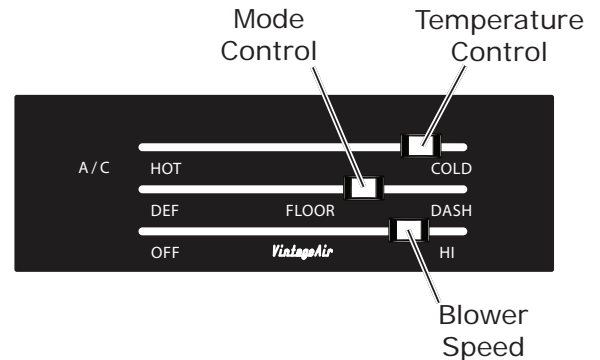

## A/C Operation

### Blower Speed

Adjust to desired speed.

### Mode Control

Adjust to desired mode position (DASH position recommended).

### Temperature Control

For A/C operation, adjust to coldest position to engage compressor (Adjust between HOT and COLD to reach desired temperature).



## Heat Operation

### Blower Speed

Adjust to desired speed.

### Mode Control

Adjust to desired mode position (FLOOR position recommended).

### Temperature Control

For maximum heating, adjust to hottest position (Adjust between HOT and COLD to reach desired temperature).



## Defrost/De-fog Operation

### Blower Speed

Adjust to desired speed.

### Temperature Control

Adjust to desired temperature.

### Mode Control

Adjust to DEFROST position for maximum defrost, or between FLOOR and DEFROST positions for a bi-level blend (Compressor is automatically engaged).







www.vintageair.com

## Packing List: Control Panel Kit (474163)

No.	Qty.	Part No.	Description
1.	1	474162	Control Panel Assembly
2.	4	182353	Screw, #8 x 1/2", Wide Head
3.	1	231520	Ground Wire, 12" White, 16 GA with 1/4" Male Spade
4.	1	232007-VUR	Control Harness, Gen IV/5 Universal

Checked By: \_\_\_\_\_  
Packed By: \_\_\_\_\_  
Date: \_\_\_\_\_

1



2



3



4



**NOTE: Images may not depict actual parts and quantities.  
Refer to packing list for actual parts and quantities.**