

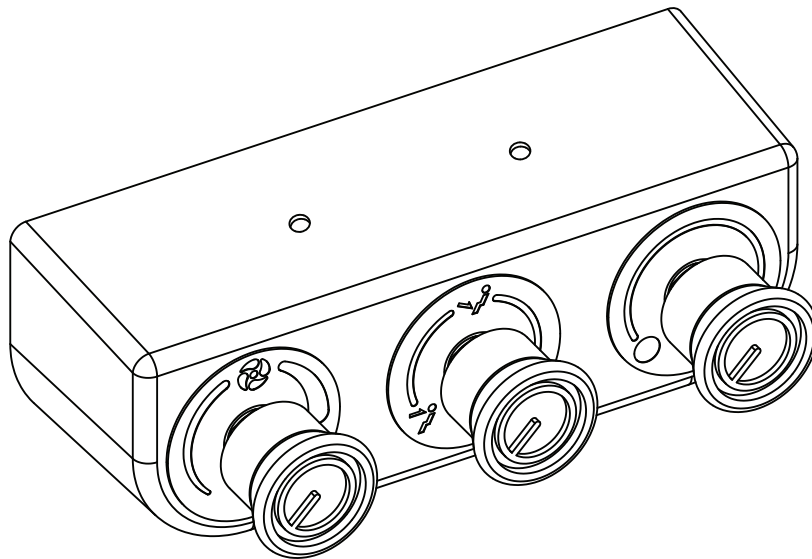

# Rotary

Control Panel Kit  
(492050)



18865 Goll St. San Antonio, TX 78266  
Phone: 800-862-6658  
Sales: [sales@vintageair.com](mailto:sales@vintageair.com)  
Tech Support: [tech@vintageair.com](mailto:tech@vintageair.com)  
[www.vintageair.com](http://www.vintageair.com)



www.vintageair.com

# Table of Contents

Cover..... 1

Table of Contents..... 2

Packing List/Parts Disclaimer..... 3

Control Panel Installation Options, Under Dash Control Panel Pod Installation..... 4

Dash Modification for In Dash Rotary Pot Installation..... 5

Rotary Pot Installation..... 6

Final Steps..... 7

Gen IV Wiring Diagram..... 8

Gen 5 Wiring Diagram..... 9

Operation of Controls..... 10

Dash Modification Template for In Dash Rotary Pot Installation..... 11

Packing List..... 12

## Important Notice—Please Read

**This control panel is designed to work with a Gen IV evaporator unit equipped with a 246204-PUA ECU (all ECU's on Gen 5 evaporators will work with this control). Please confirm that your unit has the proper ECU prior to installing the control panel as shown below. A replacement ECU can be purchased from Vintage Air if needed.**





www.vintageair.com

## Packing List: Control Panel Kit (492050)

No.	Qty.	Part No.	Description
1.	1	490006	Pod, Control Panel
2.	3	246018-0	Rotary Pot Assembly
3.	2	18235-VUB	Screw, #8 x 1/2", Pan Head
4.	3	497004	Knob, Black
5.	1	232002-VUA	Control Harness, Universal
6.	5	21301-VUP	Tie Wrap, 4"
7.	1	205550	Label, Blower Speed
8.	1	205551	Label, Mode
9.	1	205552	Label, Temperature

**\*\* Before beginning installation, open all packages and check contents of shipment. Please report any shortages directly to Vintage Air within 15 days. After 15 days, Vintage Air will not be responsible for missing or damaged items.**

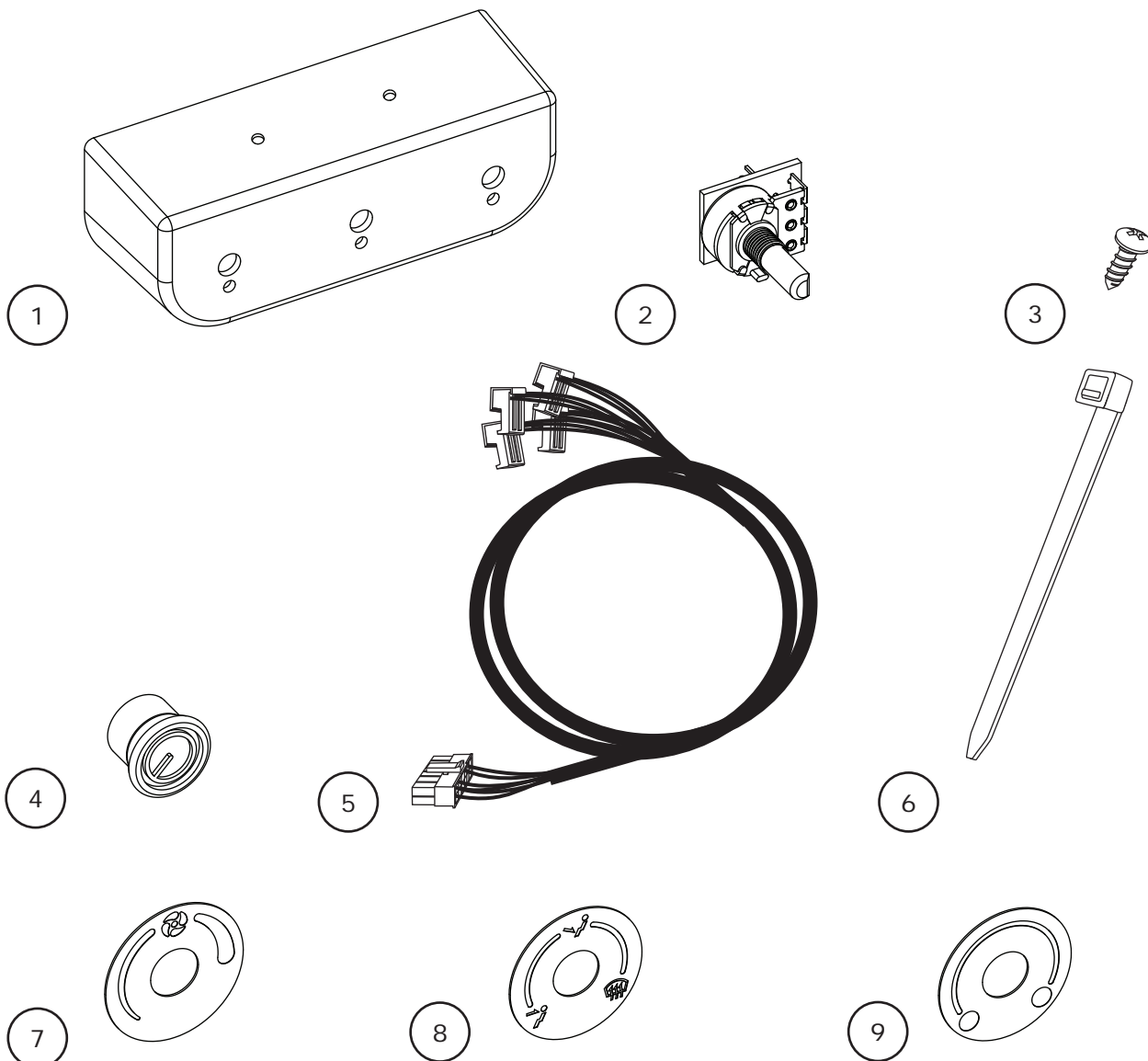

**NOTE: Images may not depict actual parts and quantities. Refer to packing list for actual parts and quantities.**



www.vintageair.com

## Control Panel Installation Options

1. The Gen IV/Gen 5 Rotary Control Panel may be installed either under the dash or in the dash.
  - A. To install the control panel under the dash using the supplied control panel pod, see Under Dash Control Panel Pod Installation below.
  - B. To install the control panel in the dash, see Dash Modification for In Dash Rotary Pot Installation on Page 5.

### Under Dash Control Panel Pod Installation

1. Install the control panel pod under the dash using (2) #8 x 1/2" pan head screws as shown in Figure 1, below.
2. See Rotary Pot Installation on Page 6.

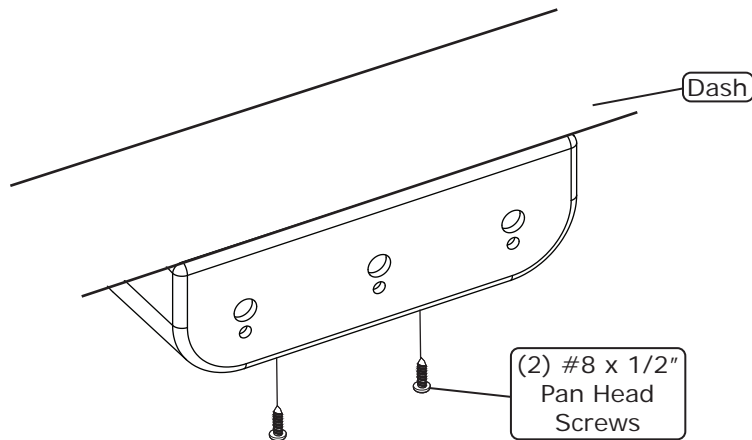

Figure 1



www.vintageair.com

## Dash Modification for In Dash Rotary Pot Installation

1. Using the template provided on Page 11, place the template onto the dash, and drill (3)  $19/64$ " holes and (3)  $5/32$ " holes into the dash as shown in Figure 2, below.
2. See Rotary Pot Installation on Page 6.

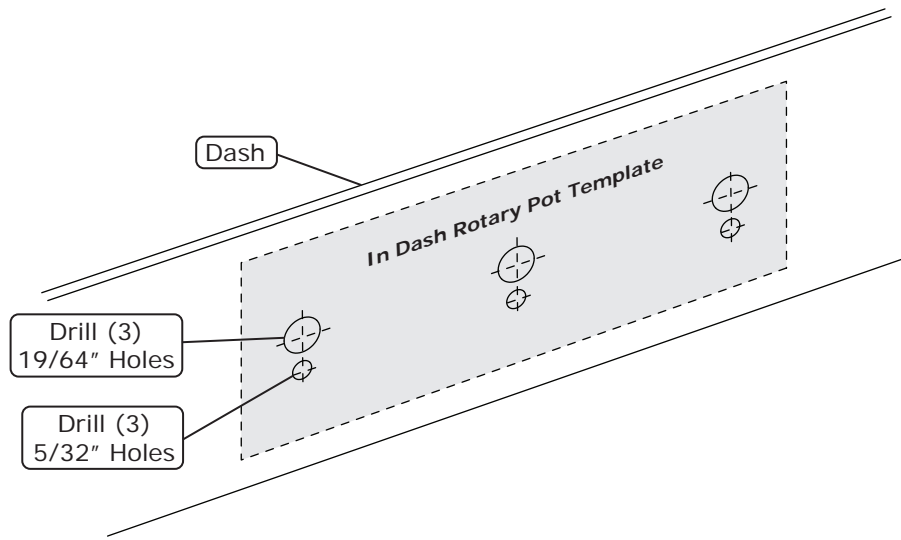
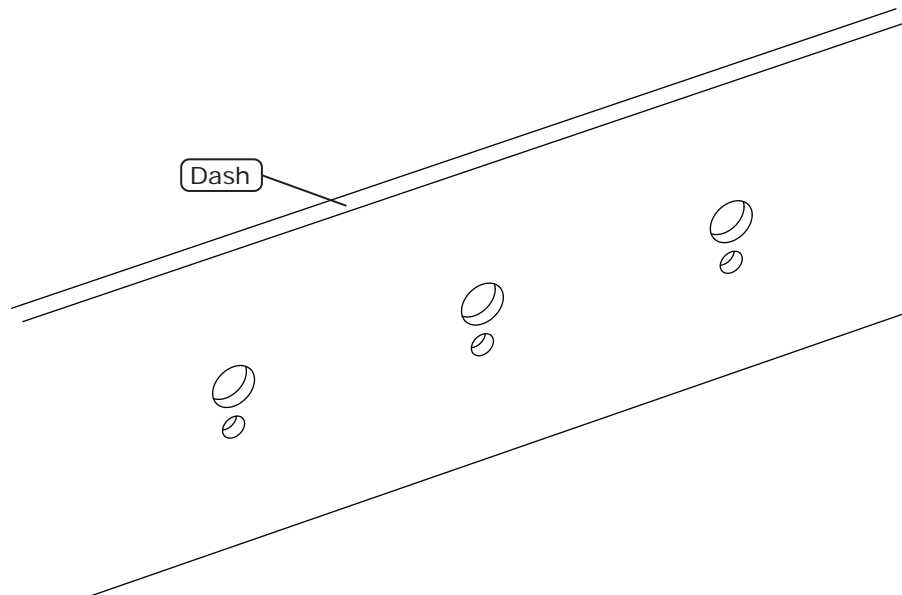

Figure 2





www.vintageair.com

# Rotary Pot Installation

1. Install (3) rotary pot assemblies into the pod or dash as shown in Figure 3, below.
2. Tie wrap the wires to the rotary pots as shown in Figure 3a, below.

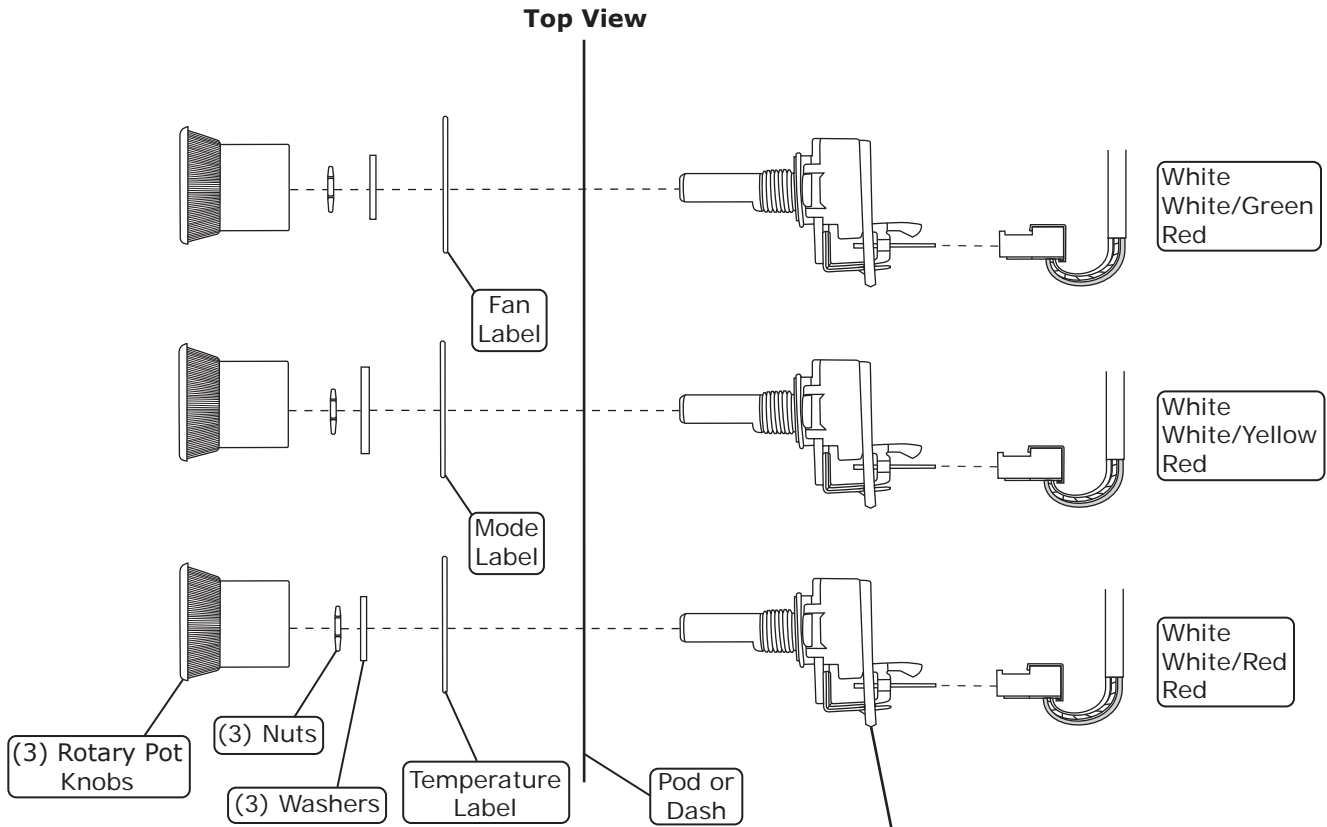

**Figure 3**

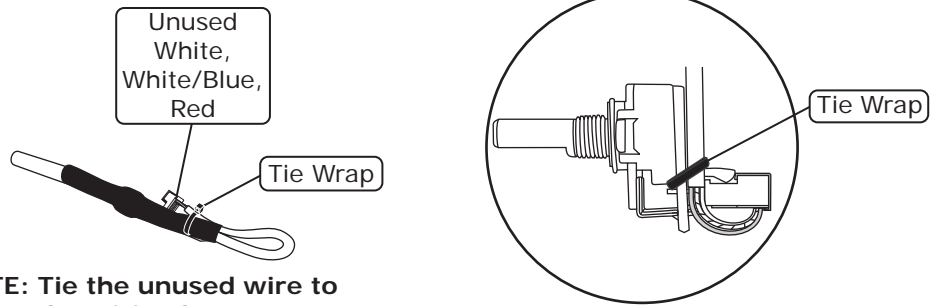

**Figure 3a**

**NOTE:** Tie the unused wire to the wiring harness as shown above.



www.vintageair.com

## Final Steps

1. Plug the wiring harnesses into the ECU module on the sub case (See Figure 4, below).
2. Wire according to the wiring diagram on Page 8 for Gen IV systems or Page 9 for Gen 5 systems.

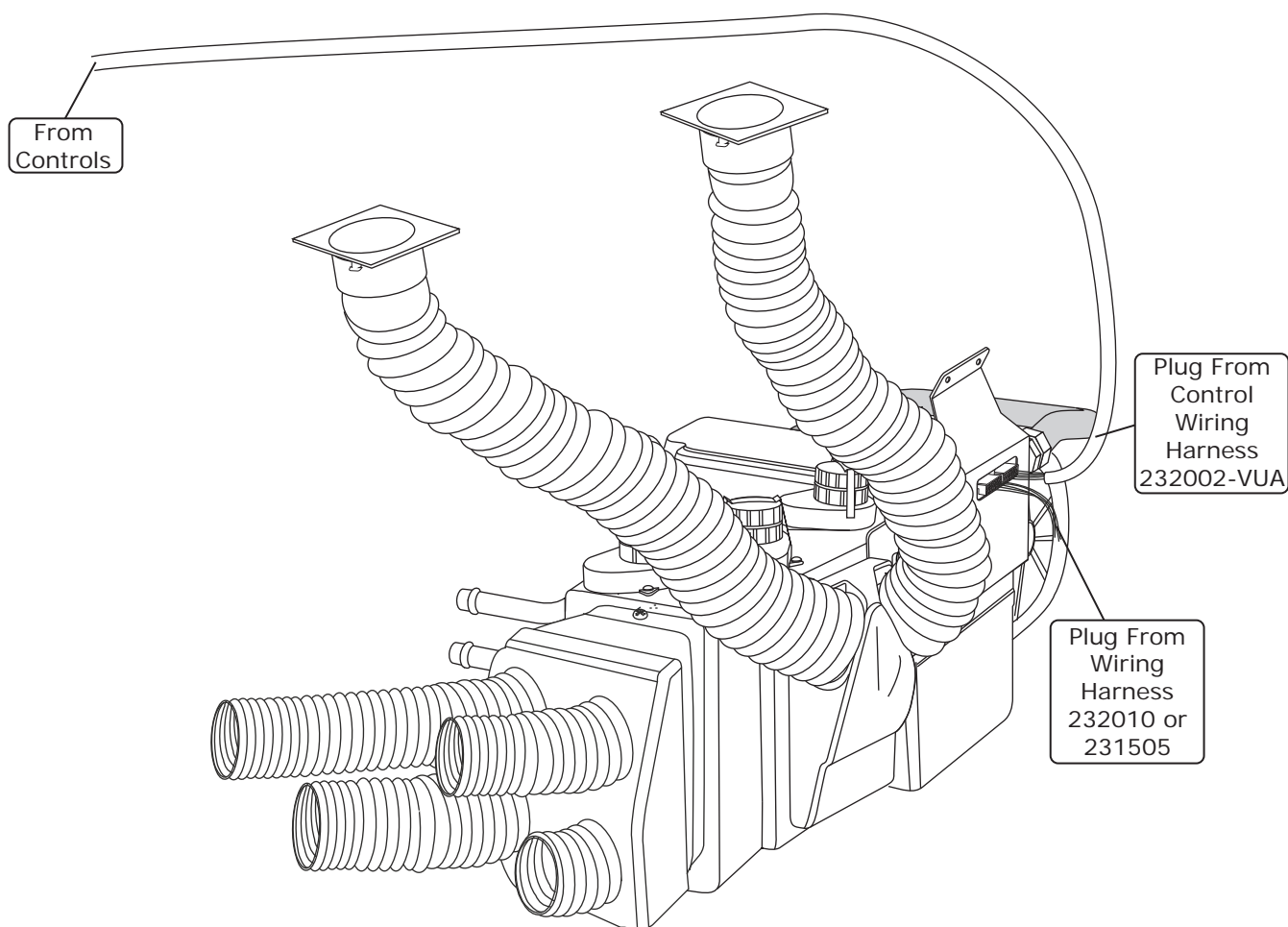
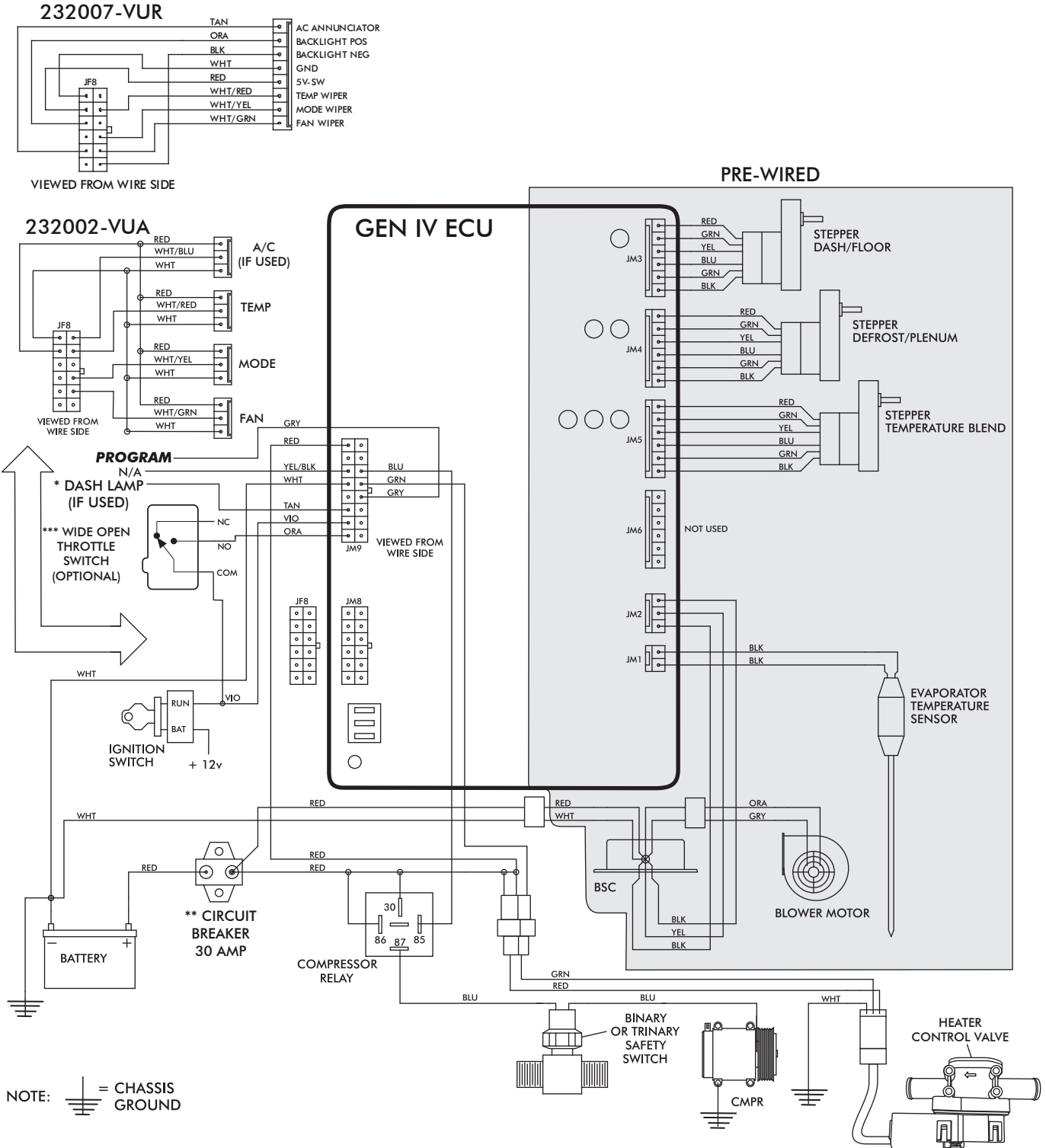

Figure 4



www.vintageair.com

# Gen IV Wiring Diagram



NOTE: = CHASSIS GROUND

- \* Dash lamp is used only with type 232007-VUR harness.
- \*\* Warning: Always mount circuit breaker as close to the battery as possible. (NOTE: Wire between battery and circuit breaker is unprotected and should be carefully routed to avoid a short circuit).
- \*\*\* Wide open throttle switch contacts close only at full throttle, which disables A/C compressor.



www.vintageair.com

# Gen 5 Wiring Diagram

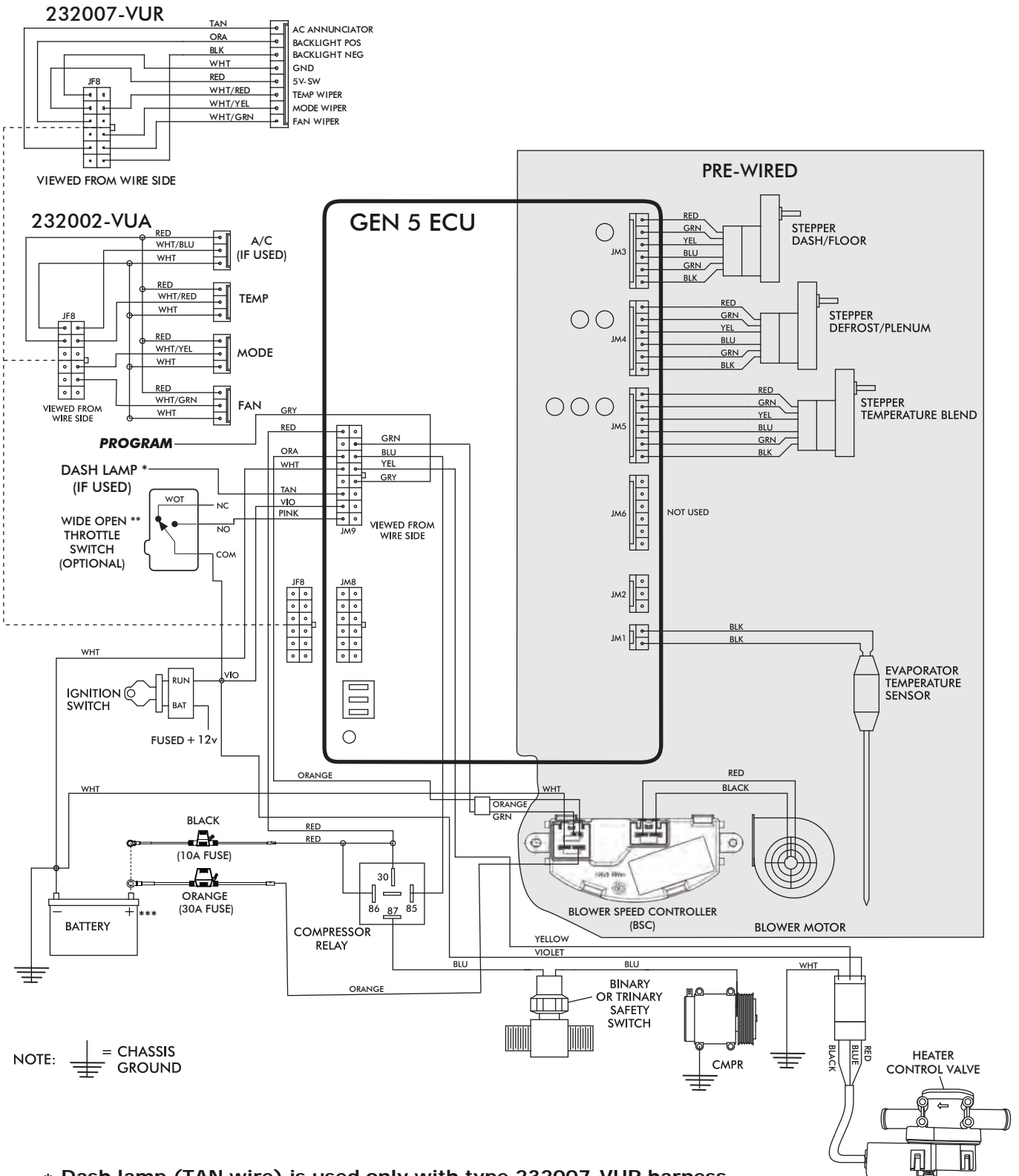

NOTE: = CHASSIS GROUND

- \* Dash lamp (TAN wire) is used only with type 232007-VUR harness.
- \*\* Wide open throttle switch contacts close only at full throttle, which disables A/C compressor.
- \*\*\* Install fuse assemblies at or as near to the battery as possible.



www.vintageair.com

## Operation of Controls

On Gen IV and Gen 5 systems with three lever/knob controls, the temperature control toggles between heat and A/C operations. To activate A/C, move the temperature lever/knob all the way to cold and then back it off to the desired vent temperature. For heat operation, move the temperature lever/knob all the way to hot and then adjust to the desired vent temperature. The blower will momentarily change speed, each time you toggle in and out of heat and A/C operations, to indicate the change.

### Blower Speed

This lever/knob controls blower speed, from OFF to HI.

### Mode Control

This lever/knob controls the mode positions, from DASH to FLOOR to DEFROST, with a blend in between.

### Temperature Control

This lever/knob controls the temperature, from HOT to COLD.

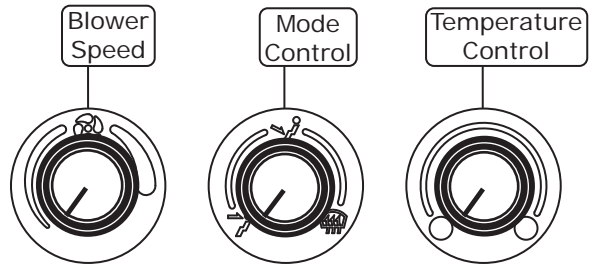

## A/C Operation

### Blower Speed

Adjust to desired speed.

### Mode Control

Adjust to desired mode position (DASH position recommended).

### Temperature Control

For A/C operation, adjust to coldest position to engage compressor (Adjust between HOT and COLD to reach desired temperature).



## Heat Operation

### Blower Speed

Adjust to desired speed.

### Mode Control

Adjust to desired mode position (FLOOR position recommended).

### Temperature Control

For maximum heating, adjust to hottest position (Adjust between HOT and COLD to reach desired temperature).



## Defrost/De-fog Operation

### Blower Speed

Adjust to desired speed.

### Temperature Control

Adjust to desired temperature.

### Mode Control

Adjust to DEFROST position for maximum defrost, or between FLOOR and DEFROST positions for a bi-level blend (Compressor is automatically engaged).



# Dash Modification Template for In Dash Rotary Pot Installation

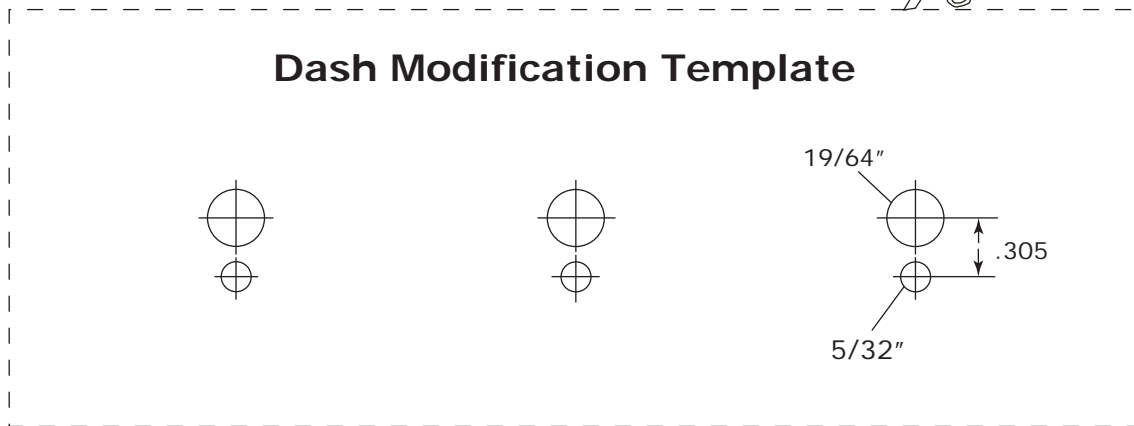

**NOTE:** Due to printing variances, measure the line below before using this template. If template is scaled properly, the line should measure 6 inches.

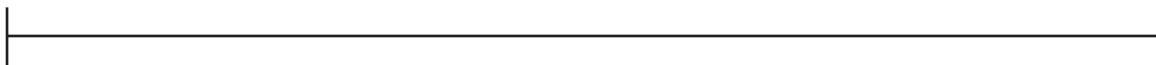







www.vintageair.com

## Packing List: Control Panel Kit (492050)

No.	Qty.	Part No.	Description
1.	1	490006	Pod, Control Panel
2.	3	246018-0	Rotary Pot Assembly
3.	2	18235-VUB	Screw, #8 x 1/2", Pan Head
4.	3	497004	Knob, Black
5.	1	232002-VUA	Control Harness, Universal
6.	5	21301-VUP	Tie Wrap, 4"
7.	1	205550	Label, Blower Speed
8.	1	205551	Label, Mode
9.	1	205552	Label, Temperature

Checked By: \_\_\_\_\_  
 Packed By: \_\_\_\_\_  
 Date: \_\_\_\_\_

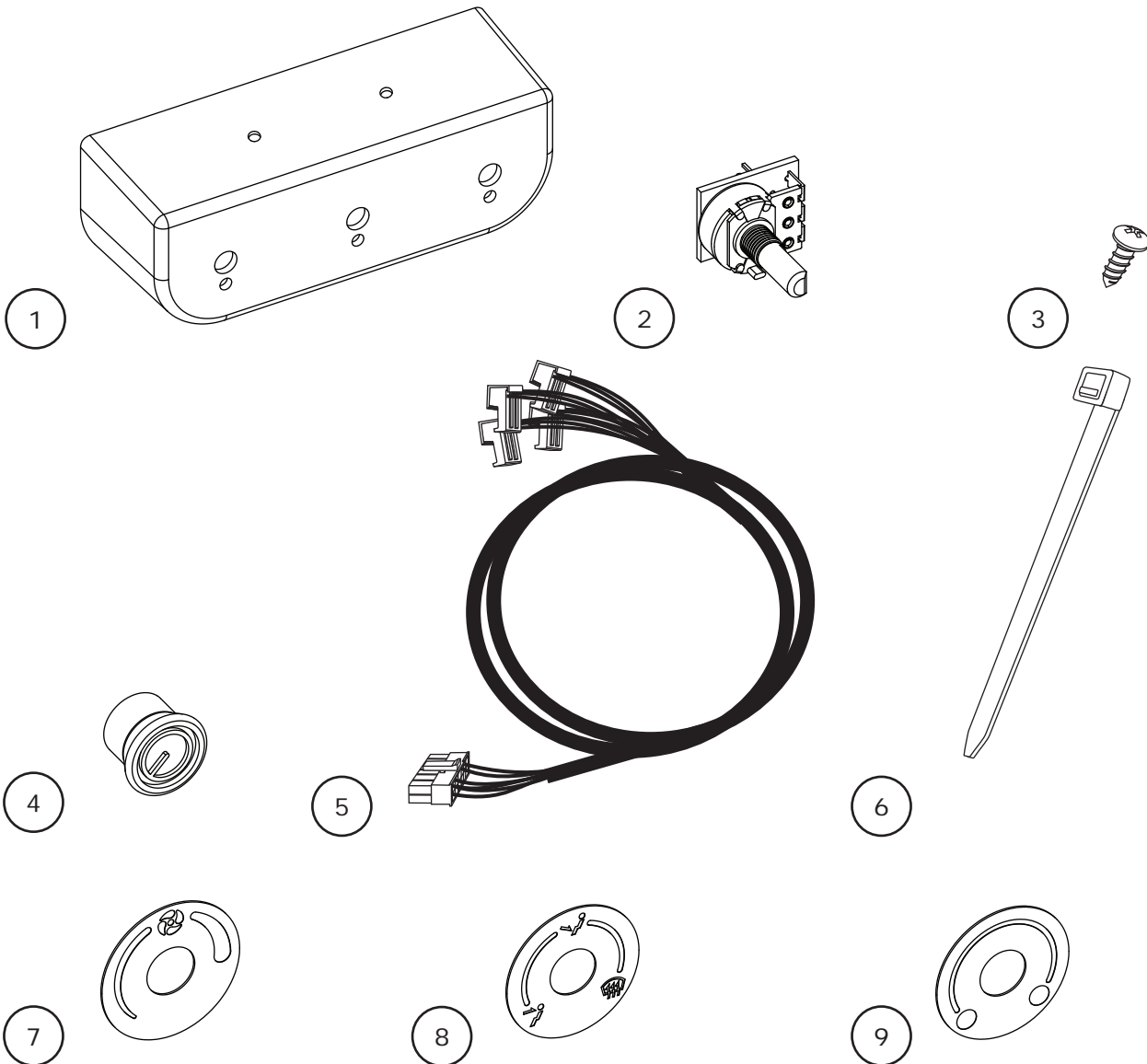

**NOTE: Images may not depict actual parts and quantities.  
 Refer to packing list for actual parts and quantities.**